

# CATÁLOGO

CATALOGUE | CATALOGUE 2024



1905







1905





# Historia

HISTORY | HISTOIRE

BOJ es una empresa familiar fundada en 1905, con sede en Eibar, una pequeña localidad situada en la provincia de Guipúzcoa, en el País Vasco, España.

La empresa se especializa en la fabricación de abrelatas, sacacorchos y otros utensilios de menaje relacionados. Cada uno de sus productos está meticulosamente diseñado y fabricado con los más altos estándares de calidad, lo que ha permitido que sean reconocidos por su durabilidad y confiabilidad entre sus clientes más exigentes.

Sin embargo, lo que hace que BOJ sea verdaderamente especial, es su enfoque en la tradición y la fabricación. La empresa se enorgullece de su historia y del legado de calidad que ha construido durante más de un siglo. Esto ha permitido que los valores y la visión se mantengan intactos a lo largo de 3 generaciones, lo que ha contribuido en gran medida a afianzar su reputación en la industria.

Además, el compromiso con la comunidad local sigue presente. La empresa colabora activamente en el desarrollo económico y social de Eibar, creando empleo y apoyando a diversas organizaciones y proyectos locales. Esta conexión con la comunidad ha hecho que BOJ se convierta en un símbolo de orgullo para los habitantes de Eibar y ha fortalecido aún más su posición en los mercados.

Actualmente, BOJ mira hacia el futuro con la misma pasión y determinación que caracterizan a la marca desde los inicios, afrontando con confianza los desafíos y perpetuando su compromiso con la excelencia.





BOJ est une entreprise familiale fondée en 1905, basée à Eibar, une petite ville de la province de Guipuzcoa, au Pays Basque, en Espagne.

L'entreprise est spécialisée dans la fabrication d'ouvre-boîtes, de tire-bouchons et d'autres ustensiles de cuisine connexes. Chaque produit est méticuleusement conçu et fabriqué selon les normes de qualité les plus élevées, ce qui leur a permis d'être reconnus pour leur durabilité et leur fiabilité parmi ses clients les plus exigeants.

Mais, ce qui fait la spécificité de BOJ, c'est l'accent mis sur la tradition et l'artisanat. L'entreprise est fière de son histoire et de l'héritage de qualité qu'elle a construit depuis plus d'un siècle. Cela a permis aux valeurs et à la vision de l'entreprise de rester intactes sur 3 générations, ce qui a grandement contribué à consolider sa réputation dans l'industrie.

En outre, l'engagement envers la communauté locale reste présent. L'entreprise contribue activement au développement économique et social d'Eibar, en créant des emplois et en soutenant diverses organisations et projets locaux. Ce lien avec la communauté a fait de BOJ un symbole de fierté pour les habitants d'Eibar et a renforcé sa position sur les marchés.

Aujourd'hui, BOJ se tourne vers l'avenir avec la même passion et la même détermination que celles qui ont caractérisé la marque depuis sa création, en relevant les défis avec confiance et en perpétuant son engagement en faveur de l'excellence.

BOJ is a family-owned company founded in 1905, based in Eibar, a small town located in the province of Guipuzcoa, in the Basque Country, Spain.

The company specializes in the manufacture of can openers, corkscrews and other related kitchenware. Each of their products is meticulously designed and manufactured to the highest quality standards, which has allowed them to be recognized for their durability and reliability among their most demanding customers.

What makes BOJ truly special, however, is their focus on tradition and craftsmanship. The company prides itself on its history and the legacy of quality it has built for more than a century. This has allowed the values and vision to remain intact over 3 generations, which have gone a long way in cementing its reputation in the industry.

In addition, the commitment to the local community is still present. The company actively collaborates in the economic and social development of Eibar, creating jobs and supporting various local

organizations and projects. This connection with the community has made BOJ a symbol of pride for the inhabitants of Eibar and has further strengthened its position in the markets.

Today, BOJ looks to the future with the same passion and determination that have characterized the brand since the beginning, confidently facing challenges and perpetuating its commitment to excellence.

# Leyenda | Legend | Légende



**Unidades por caja**  
Units per box  
Unités par boîte



**Inducción**  
Induction  
Induction



**Cápsulas E.S.E.**  
E.S.E. capsules  
Capsules E.S.E.



**Presentación en Blister**  
Blister presentation  
Présentation sous blister



**Vitrocerámica**  
Ceramic glass  
Verre céramique



**Cápsulas Nespresso**  
Capsules / ground coffee  
Capsules / café moulu



**Presentación en Estuche**  
Box presentation  
Présentation en Étui



**Cocina eléctrica**  
Electric kitchen  
Cuisine électrique



**Café molido**  
Ground coffee  
Café moulu



**Presentación en Corbata**  
Presentation in Tie  
Présentation en Cravate



**Gas**  
Gas  
Gaz



**Vaporizador**  
Vaporizer  
Vaporisateur



**Presentación en Expositor**  
Presentation in Display  
Présentoir en Expositant



**Hierro**  
Iron  
Fer



**Cable USB**  
USB wire  
Cable USB



**Número de Botellas**  
Number of Bottles  
Nombre de Bouteilles



**Aluminio**  
Aluminum  
Aluminium



**Bares de Presión**  
Pressure Bars  
Barres de pression



**Capacidad en Litros**  
Capacity in Liters  
Capacité en Litres



**Acero Inoxidable**  
Stainless Steel  
Acier inoxydable



**Potencia W**  
Power W  
Puissance W



**Número de baldas**  
Number of shelves  
Nombre d'étagères



**Fondo difusor sándwich**  
Sandwich diffuser base  
Fond diffuseur sandwich



**Capacidad L**  
Capacity L  
Capacité L



**Sistema No frost**  
No frost system  
Système No frost



**Antiadherente ILAG**  
ILAG non-stick  
ILAG antiadhésif



**Función recalentar**  
Reheat function  
Fonction de réchauffage



**Pantalla táctil**  
Touch pad  
Écran tactile



**Apto para horno**  
Oven safe  
Passe au four



**Función descongelar**  
Defrost function  
Fonction de dégivrage



**Iluminación LED**  
LED lighting  
Éclairage LED



**Apto para lavavajillas**  
Dishwasher safe  
Lave-vaisselle



**Basculante**  
Tilting  
Inclinaison



**Bloqueo infantil**  
Child lock  
Sécurité enfants



**Calificación energética**  
Energy Rating  
Classe énergétique



**Giratorio**  
Rotating  
Rotatif

# INDEX

## Abrelatas Industriales

INDUSTRIAL CAN OPENERS | OUVRE-BOÎTES INDUSTRIELS

13

### Abrelatas Industriales

INDUSTRIAL CAN OPENERS • OUVRE-BOÎTES INDUSTRIELS

15

Abrelatas Industrial Desmontable NSF	Removable NSF Industrial CAN OPENER	OUVRE-BOÎTES Industriel Amovible NSF	16
ABRELATAS Industrial Tradicional	Traditional Industrial CAN OPENER	OUVRE-BOÎTES Industriel Traditionnel	16

## Accesorios de Bar

BAR ACCESSORIES | ACCESSOIRES DE BAR

19

### Sacacorchos de Pared

WALL-MOUNTED CORKSCREWS • TIRE-BOUCHONS MUREAUX

21

Sacacorchos de pared TRADICIONAL	TRADITIONAL wall-mounted corkscrew	Tire-bouchon mural TRADITIONNEL	22
Sacacorchos de pared 110	110 wall-mounted corkscrew	Tire-bouchon mural 110	24
Sacacorchos de pared 110 LUX	110 LUX wall-mounted corkscrew	Tire-bouchon mural 110 LUX	26

### Sacacorchos de mesa

TABLE-MOUNTED CORKSCREWS • TIRE-BOUCHONS DE COMPTOIR

30

### Repuestos Sacacorchos

SPARE PARTS FOR CORKSCREW • PIÈCES DÉTACHÉES POUR TIRE-BOUCHON

31

### Sacacorchos de Mano

HAND CORKSCREWS • TIRE-BOUCHONS À MAIN

32

Sacacorchos doble palanca BÚHO	Double lever corkscrew OWL	Tire-bouchon double levier HIBOU	32
Sacacorchos doble palanca BÚHO LUX	Double lever corkscrew OWL LUX	Tire-bouchon double levier HIBOU LUX	33
Sacacorchos BODEGA	CELLAR Corkscrew	Tire-bouchon BODEGA	34
Sacacorchos BODEGA LUX	CELLAR LUX Corkscrew	Tire-bouchon BODEGA LUX	35
Sacacorchos KEA LUX	KEA LUX Corkscrew	Tire-bouchon KEA LUX	36

### Cortacápsulas Cap-Cut

CAP-CUT FOIL CUTTERS • COUPE-CAPSULES CAP-CUT

38

### Sacacorchos de Mano

HAND CORKSCREWS • TIRE-BOUCHONS À MAIN

40

### Accesorios para bebidas

DRINK ACCESSORIES • ACCESSOIRES POUR BOISSONS

42

### Sets de Vino Inox

WINE SETS Inox • COFFRETS À VIN Inox

48

## Vinotecas

WINE COOLERS | CAVES À VIN

51

### Encastrable Bajo Encimera

BUILT-IN UNDERCOUNTER • ENCASTRÉE SOUS COMPTOIR

52

Vinoteca Encastrable W-0821	Built-in Undercounter Wine Cellar W-0821	Cave à Vin Encastrée sous comptoir W-0821	52
Vinoteca Encastrable W-0820	Built-in Undercounter Wine Cellar W-0820	Cave à Vin Encastrée sous comptoir W-0820	53

### Integrable en Columna

INTEGRABLE IN COLUMN • INTÉGRABLE EN COLONNE

54

Vinoteca Integrable W-0455	Fully Integrable Wine Cellar W-0455	Cave à Vin Intégrable W-0455	54
Vinoteca Integrable W-0595	Fully Integrable Wine Cellar W-0595	Cave à Vin Intégrable W-0595	55

### Libre Instalación

FREE INSTALLATION • POSE LIBRE

56

Vinoteca Libre Instalación W-1285	Free Standing Wine Cellar W-1285	Cave à Vin Autoportante W-1285	56
Vinoteca Libre Instalación W-1770	Free Standing Wine Cellar W-1770	Cave à Vin Autoportante W-1770	57

## Menaje

KITCHENWARE | MÉNAGE

59

### Baterías de Cocina y Sartenes

COOKWARE AND FRYING PANS • USTENSILES DE CUISINE ET POÊLES

60

Batería de Cocina PREMIUM	PREMIUM Cookware	Ustensiles de Cuisine PREMIUM	60
Batería de Cocina NEW CLASSIC	NEW CLASSIC Cookware	Ustensiles de Cuisine NEW CLASSIC	62
Sartenes PREMIUM COAT	PREMIUM COAT frying pan	Poêle PREMIUM COAT	64
Olla a Presión CLASSIC	CLASSIC Pressure Cooker	Autocuiseur CLASSIC	65
Olla Rápida a Presión LIGHTNING	LIGHTNING Rapid Pressure Cooker	Autocuiseur Rapide LIGHTNING	66
Olla Rápida a Presión HORIZON	HORIZON Rapid Pressure Cooker	Autocuiseur Rapide HORIZON	68

### Pequeño Menaje

SMALL KITCHENWARE | PETIT MÉNAGE

69

### Cafeteras y Termos

COFFEE MAKERS AND THERMOS • CAFETIÈRES ET THERMOS

71

Cafeteras	Coffee makers	Cafetière	71
Termos	Thermos	Thermos	72

### Jamoneros

HAM HOLDERS • PORTE-JAMBONS

73

### Utensilios de Cocina

KITCHEN UTENSILS • USTENSILES DE CUISINE

74

## Minidomésticos

SMALL APPLIANCES | PETIT ÉLECTROMÉNAGER

69

## Minidomésticos

SMALL APPLIANCES • PETIT ÉLECTROMÉNAGER

83

Cafetera Espresso/Capuchino ALBA	Espresso/Capuccino Machine ALBA	Machine à Espresso/Capuccino ALBA	85
Cafetera Italiana Eléctrica Negra	Electric Moka Coffee Maker Black	Cafetière Moka Électrique Noir	86
Molinillo para café y especias CG-30	Coffee and spice Grinder CG-30	Moulin à café et épices CG-30	86
Cafetera Portátil GIRO	GIRO Portable Coffee Maker	Cafetière Portable GIRO	87
Tostadoras	Toasterers	Grille-pains	88
Exprimidor con Palanca JE-101X	Juice extractor with Lever JE-101X	Presse-agrumes à Levier JE-101X	90
Hervidor de agua KT-1700X	Kettle KT-1700X	Bouilloire KT-1700X	90
Barbacoas	Grill Barbecues	Grill Barbecues	91
Batidoras	Blenders	Mixeurs	92
Cortafiambres MS-15	Slicer MS-15	Trancheuse MS-15	95
Freidora F-2500	Deep Fryer F-2500	Friteuse F-2500	95
Robots Amasador	Stand Mixers	Robots Pâtissier	96
Procesador de Alimentos FP-3500X	Food Processor FP-3500X	Robot de Cuisine FP-3500X	98
Robots de Cocina	Multifunctional Cookers	Robots de Cuisine	98
Olla a Presión de Inducción	Programmable Induction	Autocuiseur Induction	
Programable PC-1100-5	PressureCooker PC-1100-5	Programmable PC-1100-5	100

## Repuestos

SPARE PARTS | PIÈCES DÉTACHÉES

101



# Abrelatas Industriales

INDUSTRIAL CAN OPENERS | OUVRE-BOÎTES INDUSTRIELS







# Abrelatas Industriales

## Industrial Can openers

## Ouvre-boîtes Industriels

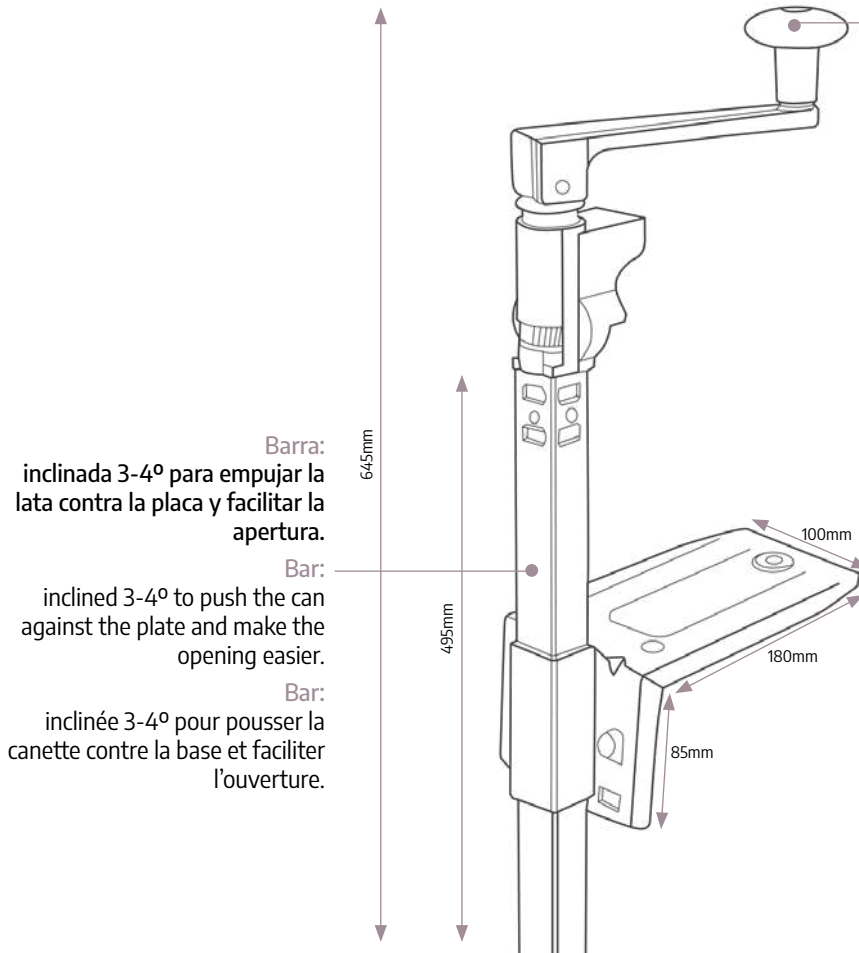

Empuñadura:  
**ergonómica.**  
 Knob:  
 ergonomic.  
 Poignée:  
 ergonomique.

Barra:  
 inclinada 3-4° para empujar la  
 lata contra la placa y facilitar la  
 apertura.

Bar:  
 inclined 3-4° to push the can  
 against the plate and make the  
 opening easier.

Bar:  
 inclinée 3-4° pour pousser la  
 canette contre la base et faciliter  
 l'ouverture.

Doble refuerzo para un ajuste más firme:  
 base atornillada y base de sujeción  
 en acero inoxidable o níquel según el  
 modelo.

Double reinforcement for a tighter fit:  
 screw down base and clamp base in  
 stainless steel or nickel depending on the  
 model.

Double renfort pour une meilleure tenue:  
 base vissée et base de fixation en acier  
 inoxydable ou nickel selon le modèle.



Latas:  
 abre latas de hasta 40-45cm.

Cans:  
 opens cans up to 40-45 cm.

Canettes:  
 ouvre des boîtes jusqu'à 40-45 cm.



## Abrelatas Industrial Desmontable NSF

Removable NSF Industrial Can opener  
Ouvre-boîtes Industriel Amovible NSF



Desmontaje rápido:  
sin herramientas y apto lavavajillas.  
Quick change:  
tool-free disassembly, dishwasher safe.  
Démontage rapide:  
sans outils et passe au lave-vaisselle.



Niquelado  
Nickel Plated  
Nickelé  
REF: 00111704  
EAN: 8425131011176



Acero Inoxidable  
Stainless Steel  
Acier inoxydable  
REF: 00111804  
EAN: 8425131011183

## Abrelatas Industrial Tradicional

Traditional Industrial Can opener  
Ouvre-boîtes Industriel Traditionnel



Niquelado  
Nickel Plated  
Nickelé  
REF: 00110904  
EAN: 8425131011091



Acero Inoxidable  
Stainless Steel  
Acier inoxydable  
REF: 00111304  
EAN: 8425131011138

## Repuestos | Spare parts | Pièces détachées



### Cuchilla y roldana:

Reversibles, templadas y carbonitruradas.

Diseñadas para facilitar el trabajo al máximo y fabricadas con un tratamiento termo-químico denominado carbonitruración.

### Blade and gear wheel:

Reversible, tempered and carbonitrided.

Designed to make work as easy as possible and manufactured with a thermo-chemical treatment called carbonitriding.

### Lame et molette:

Réversibles, trempées et carbonitrurées.

Conçues pour rendre le travail aussi simple que possible et fabriquées avec un traitement thermochimique appelé carbonituration.

### Roldana abrelatas industrial

Industrial can opener gear wheel

Molette ouvre-boîtes industriel



El tratamiento de **carbonitruración** le proporciona dureza y resistencia al desgaste, alargando así la vida útil del abrelatas. Diámetro 27mm.

The **carbon crushing** treatment provides hardness and resistance to wear, thus extending the useful life of the can opener. Diameter 27mm.

Le traitement de **broyage du carbone** apporte dureté et résistance à l'usure, prolongeant ainsi la durée de vie utile de l'ouvre-boîtes. Diamètre: 27mm.



REF: 011071202  
EAN: 842513110718

### Cuchilla abrelatas industrial desmontable NSF

Removable NSF industrial can opener Blade

Lame ouvre-boîtes industriel amovible NSF



REF: 011171302  
EAN: 8425131171306

### Cuchilla abrelatas industrial TRADICIONAL

TRADITIONAL industrial can opener Blade

Lame ouvre-boîtes industriel TRADITIONNEL



REF: 011071302  
EAN: 8425131071309

El tratamiento de **carbonitruración** le proporciona dureza y resistencia al desgaste, alargando así la vida útil del abrelatas (hasta 2.500 latas).

The **carbon crushing** treatment provides hardness and resistance to wear, thus extending the useful life of the can opener (up to 2,500 cans).

Le traitement de **broyage du carbone** apporte dureté et résistance à l'usure, prolongeant ainsi la durée de vie utile de l'ouvre-boîte (jusqu'à 2 500 canettes).



# Accesorios de Bar

BAR ACCESSORIES | ACCESSOIRES DE BAR

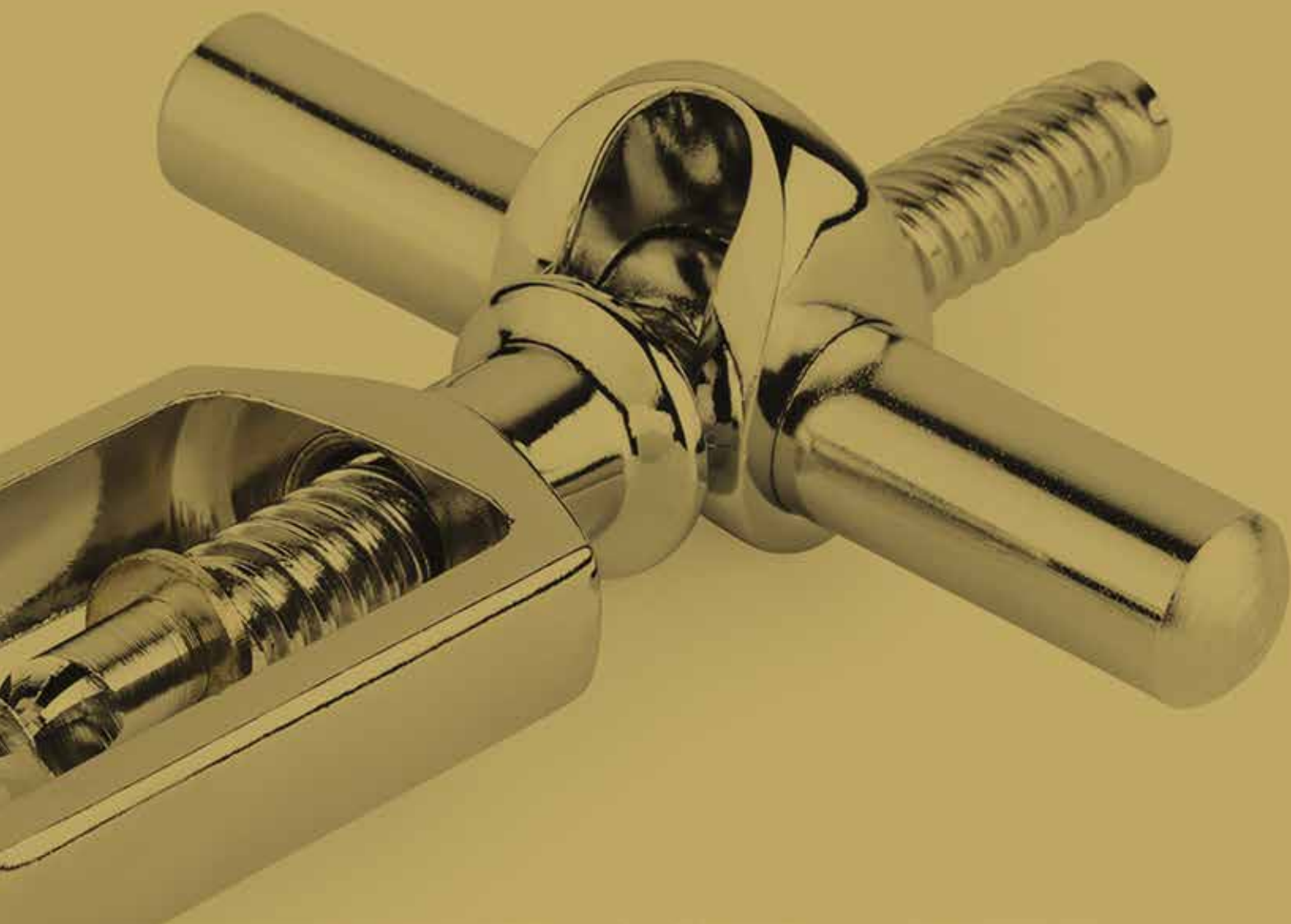





## Sacacorchos de Pared

### Wall-mounted Corkscrew

### Tire-bouchon Mural



• Acero Zamak  
Zamak Steel  
Acier Zamak

**Palanca:**  
reduce al máximo el esfuerzo a realizar para extraer el corcho de la botella.

**Lever:**  
minimizes the effort required to extract the cork from the bottle.

**Levier:**  
réduit au minimum l'effort nécessaire pour extraire le bouchon de la bouteille.

**Regulador de profundidad:**  
permite regular la medida de la salida de la espiga para que se adapte a diferentes tipos de botellas y corchos.  
3 posiciones en el Tradicional y 2 para los 110 & 110 LUX.

**Depth regulator:**  
allows to regulate the exit of the worm, while adapting it to different types of bottles and corks.  
3 positions in the Traditional and 2 in the 110 & 110 LUX.

**Régulateur de profondeur:**  
permet d'ajuster la taille de la sortie de la mèche pour qu'il s'adapte aux différents types de bouteilles et bouchons.  
3 positions pour le Traditionnel et 2 pour le 110 & 110 LUX.

**Espiga:**  
extrae los corchos naturales y sintéticos con la máxima facilidad.

**Worm:**  
capable of extracting natural and synthetic corks with maximum ease.

**Mèche:**  
capable d'extraire les bouchons naturels et synthétiques avec une facilité maximale.

**Pinza sujetabotellas:**  
sujeta perfectamente el cuello de la botella sin necesidad de tocarla para que la espiga entre recta dentro del corcho.

**Bottle clamp:**  
perfectly holds the neck of the bottle without having to touch it so that the worm fits straight into the cork.

**Pince à bouteille:**  
maintient parfaitement le goulot de la bouteille sans avoir à le toucher pour que la mèche s'insère directement dans le bouchon.



# Sacacorchos de Pared TRADICIONAL

## TRADITIONAL Wall-mounted Corkscrew

### Tire-bouchon Mural TRADITIONNEL



**Cromado**  
Chrome-plated  
Chromé  
REF: 00992104  
EAN: 8425131099129



**Níquel negro**  
Black-nickel  
Nickel noir  
REF: 00992404  
EAN: 8425131099242



**Cobre envejecido**  
Old-copper  
Cuivre vieilli  
REF: 00992504  
EAN: 8425131099259



**Cromado / soporte sapeli**  
Chrome-plated / sapele backing  
Chromé / support en sapelli  
REF: 00992104  
EAN: 8425131099211



**Níquel negro / soporte sapeli**  
Black-nickel / sapele backing  
Noir Nickel / support en sapelli  
REF: 00992604  
EAN: 8425131099266



**Cobre envejecido / soporte sapeli**  
Old-copper / sapele backing  
Cuivre vieilli / support en sapelli  
REF: 00992704  
EAN: 8425131099273



**Cromado mate**  
 Chrome matted  
 Chromé mat  
 REF: 00993904  
 EAN: 8425131099396



**Negro**  
 Black  
 Noir  
 REF: 01040604  
 EAN: 8425131104069



**Bañado en oro 24K**  
 24K Gold-plated  
 Plaqué or 24K  
 REF: 01046004  
 EAN: 8425131104601



**Cromo mate / soporte roble**  
 Chrome matted / oak backing  
 Chromé mat / support en chêne  
 REF: 00994104  
 EAN: 8425131099419



**Negro con soporte negro**  
 Black / black backing  
 Noir / support noir  
 REF: 01045504  
 EAN: 8425131104557



**Bañado en oro 24K / soporte ébano**  
 24K Gold Plated / ebony backing  
 Plaqué or 24K / support en ébène  
 REF: 01046104  
 EAN: 8425131104618



# Sacacorchos de Pared 110

## 110 Wall-mounted Corkscrew

### Tire-bouchon Mural 110



**Cromado**  
Chrome-plated  
Chromé  
REF: 01040704  
EAN: 8425131104076



**Cobre envejecido**  
Old-coppered  
Cuivre vieilli  
REF: 01040804  
EAN: 8425131104083



**Níquel negro**  
Black-nickeled  
Nickel noir  
REF: 01040904  
EAN: 8425131104090



**Cromado con soporte ceniza**  
Chrome-plated / ash backing  
Chromé / support cendre  
REF: 01045704  
EAN: 8425131104571



**Cobre envejecido / soporte ceniza**  
Old-coppered / ash backing  
Cuivre vieilli / support cendre  
REF: 01045804  
EAN: 8425131104588



**Níquel negro / soporte roble**  
Black-nickeled / oak backing  
Nickel Noir / support chêne  
REF: 01045904  
EAN: 8425131104595



**Negro**  
Black  
Noir

REF: 01041004  
EAN: 8425131104106



**Natural**  
Natural  
Naturel

REF: 01041404  
EAN: 8425131104144



**Negro / soporte roble**  
Black / oak backing  
Noir / support chêne  
REF: 01046204  
EAN: 8425131104625



**Natural / soporte roble**  
Natural / oak backing  
Naturel / support chêne  
REF: 01046504  
EAN: 8425131104656



# Sacacorchos de Pared 110 LUX

## 110 LUX wall-mounted Corkscrew

### Tire-bouchon mural LUX 110



**Rojo cereza**  
Cherry red  
Rouge cerise  
REF: 01042104  
EAN: 8425131104212



**Gris acero**  
Steel grey  
Gris acier  
REF: 01042204  
EAN: 8425131104229



**Ocre suave**  
Ochre brown  
Ocre doux  
REF: 01042304  
EAN: 8425131104236



**Rojo cereza / soporte gris oscuro**  
Cherry red / dark grey backing  
Rouge cerise / support gris foncé  
REF: 01044104  
EAN: 8425131104410



**Gris acero / soporte topo**  
Steel grey / taupe backing  
Gris acier / support taupe  
REF: 01044204  
EAN: 8425131104427



**Ocre suave / soporte gris oscuro**  
Ochre brown / dark grey backing  
Ocre doux / support gris foncé  
REF: 01044304  
EAN: 8425131104434



**Azul starnight**  
Starnight blue  
Bleu starnight  
REF: 01042404  
EAN: 8425131104243



**Verde esmeralda**  
Emerald green  
Vert émeraude  
REF: 01042504  
EAN: 8425131104250



**Azul habana**  
Habana blue  
Bleu habane  
REF: 01042604  
EAN: 8425131104267



**Azul starnight / soporte gris claro**  
Starnight blue / light grey backing  
Bleu starnight / support gris clair  
REF: 01044404  
EAN: 8425131104441



**Verde esmeralda / soporte gris oscuro**  
Emerald green / dark grey backing  
Vert émeraude / support gris foncé  
REF: 01044504  
EAN: 8425131104458



**Azul habana / soporte gris oscuro**  
Habana blue / dark grey backing  
Bleu habane / support gris foncé  
REF: 01044604  
EAN: 8425131104465



**Marrón café**  
Coffee brown  
Marrón café  
REF: 01042704  
EAN: 8425131104274



**Negro puro**  
Pure black  
Noir pur  
REF: 01042804  
EAN: 8425131104281



**Marrón café / soporte topo**  
Coffee brown / taupe backing  
Marrón café / support taupe  
REF: 01044704  
EAN: 8425131104472



**Negro puro / soporte gris oscuro**  
Pure black / dark grey backing  
Noir pur / support gris foncé  
REF: 01044804  
EAN: 8425131104489



# Soportes para Sacacorchos de pared

## Backing for wall-mounted Corkscrew

### Support pour Tire-bouchon mural

TRADICIONAL | TRADITIONAL | TRADITIONNEL



**Negro**  
Black  
Noir  
REF: 01049902  
EAN: 8425131104991



**Ébano**  
Ebony  
Ebène  
REF: 01049802  
EAN: 8425131104984



**Sapeli**  
Sapele  
Sapelli  
REF: 00992002  
EAN: 8425131099204



**Roble**  
Oak  
Chêne  
REF: 00993802  
EAN: 8425131099389

110 & 110 LUX



**Ceniza**  
Ash  
Cendre  
REF: 01049702  
EAN: 8425131104977



**Roble**  
Oak  
Chêne  
REF: 01049602  
EAN: 8425131104960



**Gris claro**  
Light grey  
Gris clair  
REF: 01049202  
EAN: 8425131104922



**Topo**  
Taupe  
Taupe  
REF: 01049102  
EAN: 8425131104915



**Gris oscuro**  
Dark grey  
Gris foncé  
REF: 01049002  
EAN: 8425131104908

## Sacacorchos de Mesa

### Table-mounted Corkscrew

### Tire-bouchon de Comptoir



**Cromado**  
Chrome-plated  
Chromé  
REF: 00990804  
EAN: 8425131099082



**Negro**  
Black  
Noir  
REF: 00990604  
EAN: 8425131099068



**Hierro fundido**  
Cast iron  
Fonte  
REF: 00991904  
EAN: 8425131099198

Solo bajo pedido  
Only upon request  
Uniquement sur demande



# Repuestos Sacacorchos

## Spare parts for Corkscrew

### Pièces détachées pour Tire-bouchon



**Espiga sacacorchos macho pack 6**  
Corkscrew male worm pack 6  
Mèche tire-bouchon mâle pack 6  
REF: 01040701  
EAN: 8425131104724



**Espiga sacacorchos hembra pack 6**  
Corkscrew female worm pack 6  
Mèche tire-bouchon femelle pack 6  
REF: 01040700  
EAN: 8425131104700



**Eficaz:**

extrae cualquier tipo de corcho independientemente de su composición. Desarrollado y fabricado en España.

**Effective:**

extracts any type of cork regardless of its composition. Developed and manufactured in Spain.

**Efficace:**

extrait tout type de liège quelle que soit sa composition. Développée et fabriquée en Espagne.



**Muelle + Tornillo tradicional**  
Traditional spring + Screw  
Ressort + Vis traditionnel  
REF: 099201802  
EAN: 8425131920188





# Sacacorchos doble palanca BÚHO

## Double lever corkscrew OWL

### Tire-bouchon double levier HIBOU

**Engranajes:**

diseñados por David Olañeta en 1932.  
Su funcionamiento sigue siendo actual.

**Gears:**

designed by David Olañeta in 1932.  
Its operation remains actual.

**Engrenages:**

conçus par David Olañeta en 1932.  
Son fonctionnement reste actuel.

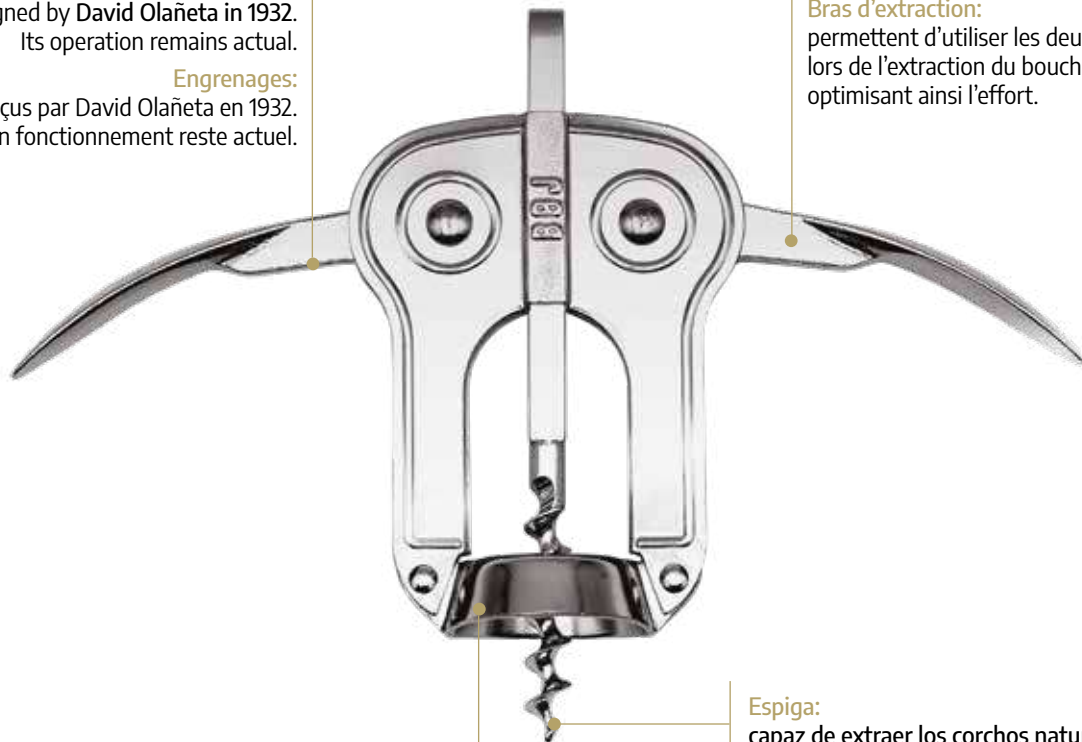

**Brazos de extracción:**

permite usar las dos manos a la hora de extraer el corcho optimizando el esfuerzo.

**Extraction arms:**

allows you to use both hands when extracting the cork, optimizing effort.

**Bras d'extraction:**

permettent d'utiliser les deux mains lors de l'extraction du bouchon, optimisant ainsi l'effort.

**Cazoleta:**

ayuda a que el cuello de la botella quede bien sujeto cuando se van a accionar los brazos de extracción.

**Cup:**

helps the neck of the bottle to remain securely in place when the extraction arms are to be operated.

**Gobelet:**

permet au goulot de la bouteille de rester bien en place lors de l'actionnement des bras d'extraction.

**Espiga:**

capaz de extraer los corchos naturales y sintéticos con la máxima facilidad.

**Worm:**

capable of extracting natural and synthetic corks with maximum ease.

**Mèche:**

capable d'extraire les bouchons naturels et synthétiques avec une facilité maximale.

**Cromado**  
Chrome-plated  
Chromé



REF: 00990301  
EAN: 8425131099037



**Negro**  
Black  
Noir



REF: 0101030401  
EAN: 8425131101037



REF: 00990304  
EAN: 8425131990341



REF: 0101030404  
EAN: 8425131113443



# Sacacorchos doble palanca BÚHO LUX

## Double lever corkscrew LUX OWL

### Tire-bouchon double levier HIBOU LUX

Rojo cereza  
Cherry red  
Rouge cerise



REF: 011110101  
EAN: 8425131111012



REF: 011110104  
EAN: 8425131111142

Verde esmeralda  
Emerald green  
Vert émeraude



REF: 011110501  
EAN: 8425131111050



REF: 011110504  
EAN: 8425131111548

Gris acero  
Steel grey  
Gris acier



REF: 011110201  
EAN: 8425131111029



REF: 011110204  
EAN: 8425131111241

Azul Habana  
Habana blue  
Bleu Habane



REF: 011110601  
EAN: 8425131111067



REF: 011110604  
EAN: 8425131111647

Ocre suave  
Ochre brown  
Ocre doux



REF: 011110301  
EAN: 8425131111036



REF: 011110304  
EAN: 8425131111340

Marrón café  
Coffee brown  
Marron café



REF: 011110701  
EAN: 8425131111074



REF: 011110704  
EAN: 8425131111746

Azul starnight  
Blue starnight  
Bleu starnight



REF: 011110401  
EAN: 8425131111043



REF: 011110404  
EAN: 8425131111449

Negro puro  
Pure black  
Noir pur



REF: 011110801  
EAN: 8425131111081



REF: 011110804  
EAN: 8425131111845



# Sacacorchos BODEGA

## CELLAR Corkscrew

### Tire-bouchon BODEGA

**Mecanismo:**

permite descorchar la botella sin necesidad de moverla tal y como recomiendan los expertos.

**Mechanism:**

it allows you to uncork the bottle without having to move it, as recommended by experts.

**Mécanisme:**

il permet de déboucher la bouteille sans avoir à la déplacer, comme le recommandent les experts.



**Espiga:**

capaz de extraer los corchos naturales y sintéticos con la máxima facilidad.

**Worm:**

capable of extracting natural and synthetic corks with maximum ease.

**Mèche:**

capable d'extraire les bouchons naturels et synthétiques avec une facilité maximale.

**Cazoleta:**

ayuda a que el cuello de la botella quede bien sujeto a la hora de extraer el corcho.

**Cup:**

helps the neck of the bottle to remain securely in place when removing the cork.

**Gobelet:**

permet au goulot de la bouteille de rester bien en place lors du retrait du bouchon.

**Cromado**  
Chrome-plated  
Chromé



Blister



12 ps.

REF: 00990401  
EAN: 8425131099044



Box



6 ps.

REF: 00990404  
EAN: 8425131990440





# Sacacorchos BODEGA LUX

## LUX CELLAR Corkscrew

### Tire-bouchon BODEGA LUX

**Rojo cereza**  
Cherry red  
Rouge cerise



REF: 011000101  
EAN: 8425131100016



REF: 011000104  
EAN: 8425131100146



**Verde esmeralda**  
Emerald green  
Vert émeraude



REF: 011000501  
EAN: 8425131100054



REF: 011000504  
EAN: 8425133100540



**Gris acero**  
Steel grey  
Gris acier



REF: 011000201  
EAN: 8425131100023



REF: 011000204  
EAN: 8425131100245



**Azul Habana**  
Habana blue  
Bleu Habane



REF: 011000601  
EAN: 8425131100061



REF: 011000604  
EAN: 8425131100641



**Ocre suave**  
Ochre brown  
Ocre doux



REF: 011000301  
EAN: 8425131100030



REF: 011000304  
EAN: 8425131100344



**Marrón café**  
Coffee brown  
Marron café



REF: 011000701  
EAN: 8425131100078



REF: 011000704  
EAN: 8425131100740



**Azul starnight**  
Blue starnight  
Bleu starnight



REF: 011000401  
EAN: 8425131100047



REF: 011000404  
EAN: 8425131100443



**Negro puro**  
Pure black  
Noir pur



REF: 011000801  
EAN: 8425131100085



REF: 011000804  
EAN: 8425131100849





# Sacacorchos KEA LUX

## KEA LUX Corkscrew

### Tire-bouchon KEA LUX

**Descapsulador:**

abre fácilmente todos los botellines con su descapsulador en forma de pico.

**Bottle opener:**

easily open all the bottles with its beak-shaped decapsulator.

**Décapsuleur:**

ouvre facilement toutes les bouteilles avec son décapsuleur en forme de bec.

**Navaja:**

descapsula las botellas de vino de forma rápida y sencilla.

**Razor:**

decapsulates wine bottles quickly and easily.

**Rasoir:**

décapsule les bouteilles de vin rapidement et facilement.



**Doble impulso:**

permite descorchar cualquier botella sin apenas esfuerzo.

**Double impulse:**

allows you to uncork any bottle with little effort.

**Double impulse:**

permet de déboucher n'importe quelle bouteille avec peu d'effort.

**Espiga:**

capaz de extraer los corchos naturales y sintéticos con la máxima facilidad.

**Worm:**

capable of extracting natural and synthetic corks with maximum ease.

**Mèche:**

capable d'extraire les bouchons naturels et synthétiques avec une facilité maximale.



Rojo cereza  
Cherry red  
Rouge cerise



REF: 01710104  
EAN: 8425131171016

Verde esmeralda  
Emerald green  
Vert émeraude



REF: 01710504  
EAN: 8425131171054

Gris acero  
Steel grey  
Gris acier



REF: 01710204  
EAN: 8425131171023

Azul Habana  
Habana blue  
Bleu Habane



REF: 01710604  
EAN: 8425131171061

Ocre suave  
Ochre brown  
Ocre doux



REF: 01710304  
EAN: 8425131171030

Marrón café  
Coffee brown  
Marron café



REF: 01710704  
EAN: 8425131171078

Azul starnight  
Blue starnight  
Bleu starnight



REF: 01710404  
EAN: 8425131171047

Negro puro  
Pure black  
Noir pur



REF: 01710804  
EAN: 8425131171085



# Cortacápsulas CAP-CUT

## CAP-CUT foil cutters

### Coupe-Capsules CAP-CUT



**Forma:**  
se adapta perfectamente a la mano.

**Shape:**  
fits perfectly in the hand.

**Forme:**  
tient parfaitement dans la main.



**Cuchillas:**

sus tres cuchillas ayudan a descapsular cualquier botella con un simple movimiento de muñeca.

**Blades:**

its three blades help decap any bottle with a simple movement of the wrist.

**Lames:**

ses trois lames permettent de décapsuler n'importe quelle bouteille d'un simple mouvement du poignet.

Blanco  
White  
Blanc



Negro  
Black  
Noir



Rojo  
Red  
Rouge



REF: 0121470301  
EAN: 8425131123473



REF: 0121470401  
EAN: 8425131121479



REF: 0121470501  
EAN: 8425131122476



# Cortacápsulas CAP-CUT LUX

## CAP-CUT LUX foil cutters

### Coupe-Capsules CAP-CUT LUX

**Rojo cereza**  
 Cherry red  
 Rouge cerise



REF: 011480101  
 EAN: 8425131148018



REF: 011480104  
 EAN: 8425131148148

**Verde esmeralda**  
 Emerald green  
 Vert émeraude



REF: 011480501  
 EAN: 8425131148056



REF: 011480504  
 EAN: 8425131148544

**Gris acero**  
 Steel grey  
 Gris acier



REF: 011480201  
 EAN: 8425131148025



REF: 011480204  
 EAN: 8425131148247

**Azul Habana**  
 Habana blue  
 Bleu Habane



REF: 011480601  
 EAN: 8425131148063



REF: 011480604  
 EAN: 8425131148643

**Ocre suave**  
 Ochre brown  
 Ocre doux



REF: 011480301  
 EAN: 8425131148032



REF: 011480304  
 EAN: 842513114839

**Marrón café**  
 Coffee brown  
 Marron café



REF: 011480701  
 EAN: 8425131148070



REF: 011480704  
 EAN: 8425131148773

**Azul starnight**  
 Blue starnight  
 Bleu starnight



REF: 011480401  
 EAN: 8425131148049



REF: 011480404  
 EAN: 8425131148445

**Negro puro**  
 Pure black  
 Noir pur



REF: 011480801  
 EAN: 8425131148087



REF: 011480804  
 EAN: 8425131148841

## Sacacorchos de Mano Hand Corkscrews Tire-bouchons à Main

Sacacorchos doble impulso  
Corkscrew double impulse  
Tire-bouchon double impulse



**MENDE**  
Madera clara  
Light wood | Bois clair

REF: 00996304  
EAN: 8425131996305



**EKI**  
Inoxidable  
Stainless Steel | Inoxydable

REF: 00996404  
EAN: 8425131996404



**EGO**  
Madera negra  
Black wood | Bois noir

REF: 00996204  
EAN: 8425131996206

Sacacorchos doble impulso  
Double impulse corkscrew  
Tire-bouchon double impulse

**NEW**



**SOMMELIER**  
REF: 00996101  
EAN: 8425131099617



**SOMMELIER INOX**  
REF: 00996001  
EAN: 8425131099600



**PLUS**  
REF: 00995901  
EAN: 8425131099594

Sacacorchos ELÉCTRICO con cortacápsulas  
ELECTRIC corkscrew with capsule cutter  
Tire-bouchon ÉLECTRIQUE avec coupe-capsule



REF: 00996504  
EAN: 8425131099655

Sacacorchos de LÁMINAS  
TWO-PRONG cork extractor  
Tire-bouchon BILAME



REF: 00990504  
EAN: 8425131099051

Abridor de CHAMPÁN  
CHAMPAGNE opener  
Ouvre-bouteilles CHAMPAGNE



NEW



Cromado | Chrome-plated | Chromé



REF: 01214101  
EAN: 8425131121417

Negro | Black | Noir



REF: 01214201  
EAN: 8425131121424

Sacacorchos CAMARERO sin navaja / Niquelado  
WAITERS Corkscrew without blade / Nickel-plated  
Tire-bouchon SOMMELIER sans lame / Nickelé



Sacacorchos CAMARERO con navaja / Acero inoxidable  
WAITERS Corkscrew with blade / Stainless steel  
Tire-bouchon SOMMELIER avec lame / Acier inoxydable



REF: 00990001  
EAN: 8425131099006



REF: 00990101  
EAN: 8425131099013

# Accesorios para bebidas

## Drink accessories

### Accessoires pour boissons

Bomba de vacío con 2 tapones ICE  
Vacuum pump with 2 stoppers ICE  
Pompe à vide avec 2 bouchons ICE



REF: 01216504  
EAN: 8425131121653

Tapón de champán ICE Negro  
Champagne stopper ICE Black  
Bouchon à champagne ICE Noir



REF: 01223604  
EAN: 8425131122360

Tapón de champán ICE Cromado  
Champagne stopper ICE Chrome-plated  
Bouchon à champagne ICE Chromé



REF: 01223704  
EAN: 8425131122377

Oxigenador ICE  
Aerator ICE  
Aérateur ICE



REF: 01223404  
EAN: 8425131122346

Escanciador ICE  
Pouwer ICE  
Décanteur ICE



REF: 01223304  
EAN: 8425131122339

Enfriador oxigenador ICE  
Chiller aerator ICE  
Refroidisseur aérateur ICE



REF: 01223504  
EAN: 8425131122353

Tapón de vino. Plástico  
Wine stopper. Plastic  
Bouchon à vin. Plastique



REF: 01215301  
EAN: 8425131121530

Tapón de champán. Plástico  
Champagne stopper. Plastic  
Bouchon à champagne. Plastique



REF: 01215401  
EAN: 8425131121547

Tapón de vino. Acero inoxidable  
Wine stopper. Stainless steel  
Bouchon à vin. Acier inoxydable



REF: 01221901  
EAN: 8425131122193

Tapón de vino PREMIUM. Acero inoxidable  
PREMIUM Wine stopper. Stainless steel  
Bouchon à vin PREMIUM. Acier inoxydable



REF: 01222001  
EAN: 8425131122209

Tapón de champán. Cromado  
Champagne stopper. Chrome-plated  
Bouchon à champagne. Chromé



REF: 01213801  
EAN: 8425131121387

Bomba de vacío con 2 tapones  
Vacuum pump with 2 stoppers  
Pompe à vide avec 2 bouchons



Tapones | Stoppers | Bouchons  
REF: 01218401  
EAN: 8425131121844



REF: 01216404  
EAN: 8425131121646

Anillo antigota. Inox  
Anti-drip ring. Inox  
Collier de bacchus. Inox



REF: 01219201  
EAN: 8425131121929

Anillo antigota magnético. Inox  
Magnetic anti-drip ring. Inox  
Collier de bacchus magnétique. Inox

NEW



REF: 01219104  
EAN: 8425131121912

Oxigenador con filtro y tapón  
Aerator with filter and stopper  
Aérateur avec filtre et bouchon



REF: 01222304  
EAN: 8425131122230

Escanciador con tapón de silicona. Acero inoxidable  
Pourer with silicone stopper. Stainless steel  
Décanteur avec bouchon en silicone. Acier inoxydable



REF: 01219001  
EAN: 8425131121905

Funda enfriabotellas  
Bottle cooler  
House isotherme



Negro | Black | Noir  
REF: 01217004  
EAN: 8425131121707



Burdeos | Burgundy | Bordeaux  
REF: 01227004  
EAN: 8425131122704



Champán | Champagne | Champagne  
REF: 01237004  
EAN: 8425131123701



**Descapsulador pared**  
Wall-mounted bottle opener  
Décapsuleur mural



**Niquelado | Nickel-plated | Nickelé**

REF: 00550401  
EAN: 8425131055040

**Acero Inox | Stainless Steel | Acier Inox**

REF: 00550501  
EAN: 8425131055057

**Descapsulador Universal Niquelado**  
Universal bottle opener Nickel-plated  
Décapsuleur universel Nickelé



REF: 00550802  
EAN: 8425131355089



**Niquelado | Nickel-plated | Nickelé**

REF: 00550801  
EAN: 8425131055088

**Negro | Black | Noir**

REF: 0066080401  
EAN: 8425131066084

**Descapsulador embutido Niquelado**  
Pressing bottle opener Nickel-plated  
Décapsuleur embouti Nickelé



REF: 00550302  
EAN: 8425131410153



**Niquelado | Nickel-plated | Nickelé**

REF: 00550301  
EAN: 8425131055033

**Negro | Black | Noir**

REF: 0066030401  
EAN: 8425131062031

Portátiles magnético  
Magnetic Tool holder  
Porte-outil magnétique



REF: 01219401  
EAN: 8425131121943

Soporte cubitera. Inox  
Ice bucket support. Inox  
Support pour seau à glaçons. Inox



REF: 01315604  
EAN: 8425131131546

Cubitera. Inox  
Ice bucket. Inox  
Seau à glaçons. Inox



**1,5 L ø14cm**  
REF: 01315204  
EAN: 8425131131522

**3,8 L ø20cm**  
REF: 01315504  
EAN: 8425131131553

Cubitera doble pared con tapa. Inox  
Double wall ice bucket with lid. Inox  
Seau à glaçons double paroi avec couvercle. Inox



**1 L ø12**  
REF: 01315004  
EAN: 8425131131508

**2 L ø15**  
REF: 01315104  
EAN: 8425131131515

Cuchara Batidora cóctel. Inox  
Cocktail Mixer spoon. Inox  
Cuillère à Cocktail. Inox



REF: 01215801  
EAN: 8425131121585

Pinza para hielo con muelle. Inox  
Ice tongs with spring. Inox  
Pince à glaçons avec ressort. Inox



REF: 01314801  
EAN: 8425131331489

Pala para hielo 24 cm. Inox  
Ice scoop 24 cm. Inox  
Pelle à glaçons 24 cm. Inox



REF: 01314702  
EAN: 8425131131478

Pala para hielo 19 cm. Inox  
Ice scoop 19 cm. Inox  
Pelle à glaçons 19 cm. Inox



REF: 01314602  
EAN: 8425131131461

Petaca Brillante 235 ml. Inox  
Brighted Flask 235 ml. Inox  
Flasque Brillante 235 ml. Inox



REF: 01500204  
EAN: 8425131150028

Petaca Satinada 175 ml. Inox  
Satinated Flask 175 ml. Inox  
Flasque Satinée 175 ml. Inox



REF: 01500304  
EAN: 8425131150035

Encorchador de mano  
Hand corking machine  
Boucheuse manuelle



REF: 01213702  
EAN: 8425131121370

## Sets de Vino Inox

### Inox Wine Sets

### Coffrets à vin Inox

Anillo antigota Premium 130gr. Inox  
 Premium anti-drip ring 130gr  
 Collier de bacchus Premium 130gr



REF: 01222604  
 EAN: 8425131122261

Oxigenador de vino Premium 225gr. Inox  
 Premium Wine aerator 225gr. Inox  
 Aérateur de vin Premium 225gr. Inox



REF: 01222504  
 EAN: 8425131122247

Escanciador de vino Premium 272gr. Inox  
 Premium Wine pourer 272gr. Inox  
 Décanteur à vin Premium 272gr. Inox



REF: 01222404  
 EAN: 8425131122254

Escanciador para espumosos Premium 172gr. Inox  
 Premium Sparkling drinks pourer 172gr. Inox  
 Décanteur à vin effervescent Premium 172gr. Inox



REF: 01222704  
 EAN: 8425131122278

Tapón Premium 241gr. Inox  
 Premium stopper 241gr. Inox  
 Bouchon Premium 241gr. Inox



REF: 01222804  
 EAN: 8425131122285

Set de Vino PREMIUM 3 piezas. Inox  
PREMIUM Wine Set 3 pieces. Inox  
Set à Vin PREMIUM 3 pièces. Inox



REF: 01223004  
EAN: 8425131122308

Incluye | Include | Comprend :  
01222804 | 01222504 | 01222704

Set de Vino PREMIUM 5 piezas. Inox  
PREMIUM Wine Set 5 pieces. Inox  
Set à Vin PREMIUM 5 pièces. Inox



REF: 01222904  
EAN: 8425131122292

Incluye | Include | Comprend :  
01222804 | 01222504 | 01222704 | 01222604 | 01222404



# Vinotecas

WINE COOLERS | CAVES À VIN



# Vinoteca Encastrable W-0821

## Built-in Undercounter Wine Cellar W-0821

## Cave à Vin Encastrée sous comptoir W-0821

### W-0821-X

REF: 07112204  
EAN: 8425131711229



### W-0821-B

REF: 07112304  
EAN: 8425131711236

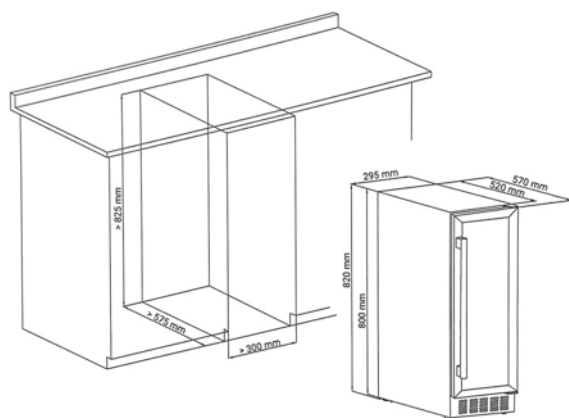

Dimensiones | Dimensions (AxFxA):  
295 x 570/520 x 820/800mm

#### Características:

Encastrables bajo encimera de 30cm. Aptas para libre instalación.  
Doble zona de temperatura con rango 5-22°C.  
Refrigeración por compresor antivibraciones.  
Balda de madera extensible.  
Puerta reversible de doble cristal con protección UV.  
Marco acero inox (X) - Cristal negro (B).  
Pies ajustables.

#### Characteristics:

Built-in under 30cm counter. Suitable for free installation  
Double temperature zone with range 5-22°C.  
Cooling by anti-vibration compressor.  
Wooden Retractable shelves.  
Reversible double glass door with UV protection.  
Stainless steel frame (X) - Black glass (B).  
Adjustable legs.

#### Caractéristiques:

Encastrée sous comptoir 30 cm. Convenient pour une libre installation.  
Zone de température double avec plage 5-22°C.  
Refroidissement par compresseur anti-vibration.  
Etagères en bois extensibles.  
Porte double vitrée réversible avec protection UV.  
Cadre inox (X) - Verre noir (B).  
Pieds réglables.



# Vinoteca Encastrable W-0820

## Built-in Undercounter Wine Cellar W-0820

### Cave à Vin Encastrée sous comptoir W-0820

#### W-0820-X

REF: 07110904  
EAN: 8425131711090



#### W-0820-B

REF: 07111204  
EAN: 8425131711205

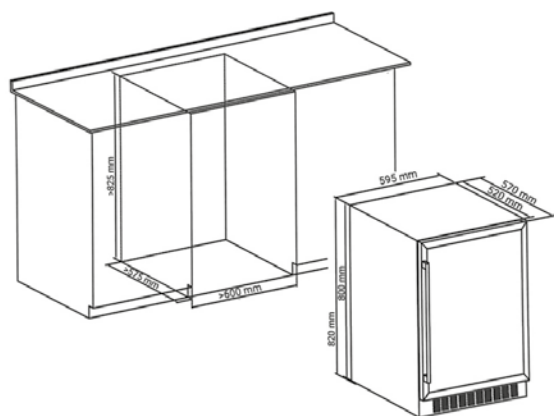

Dimensiones | Dimensions (AxFxA):  
595 x 570/520 x 820/800 mm

#### Características:

Encastrables bajo encimera de 60cm. Aptas para libre instalación.  
Doble zona de temperatura con rango 5-22°C.  
Refrigeración por compresor antivibraciones.  
Baldas de madera extensibles.  
Puerta reversible de doble cristal con protección UV.  
Marco acero inox (X) - Cristal negro (B).  
Pies ajustables.

#### Characteristics:

Built-in under 60cm counter. Suitable for free installation  
Double temperature zone with range 5-22°C.  
Cooling by anti-vibration compressor.  
Wooden Retractable shelves.  
Reversible double glass door with UV protection.  
Stainless steel frame (X) - Black glass (B).  
Adjustable legs.

#### Caractéristiques:

Encastrée sous comptoir 60cm. Convenient pour une libre installation.  
Zone de température double avec plage 5-22°C.  
Refroidissement par compresseur anti-vibration.  
Étagères en bois extensibles.  
Porte double vitrée réversible avec protection UV.  
Cadre inox (X) - Verre noir (B).  
Pieds réglables.



# Vinoteca Integrable W-0455

## Fully Integrable Wine Cellar W-0455

### Cave à Vin Intégrable W-0455

#### W-0455-X

REF: 07111604  
EAN: 8425131711168



#### W-0455-B

REF: 07111704  
EAN: 8425131711175

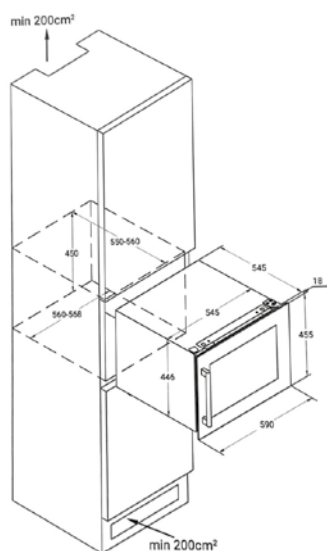

Dimensiones | Dimensions (AxFxA):  
545/590 x 545/563 x 446/455 mm

#### Características:

Integrables en columna de 45cm.  
Rango de temperatura 5-20°C.  
Refrigeración por compresor antivibraciones.  
Baldas de madera extensibles.  
Puerta reversible de doble cristal con protección UV.  
Marco acero inox (X) - Cristal negro (B).

#### Characteristics:

Integrable in 45cm column.  
Temperature range 5-20°C.  
Cooling by anti-vibration compressor.  
Wooden Retractable shelves.  
Reversible double glass door with UV protection.  
Stainless steel frame (X) - Black glass (B).

#### Caractéristiques:

Intégrable en colonne de 45cm.  
Plage de température 5-20°C.  
Refroidissement par compresseur anti-vibration.  
Étagères en bois extensibles.  
Porte double vitrée réversible avec protection UV.  
Cadre inox (X) - Verre noir (B).



# Vinoteca Integrable W-0595

## Fully Integrable Wine Cellar W-0595

### Cave à Vin Intégrable W-0595

#### W-0595-X

REF: 07111904  
EAN: 8425131711199



#### W-0595-B

REF: 07112004  
EAN: 8425131719201

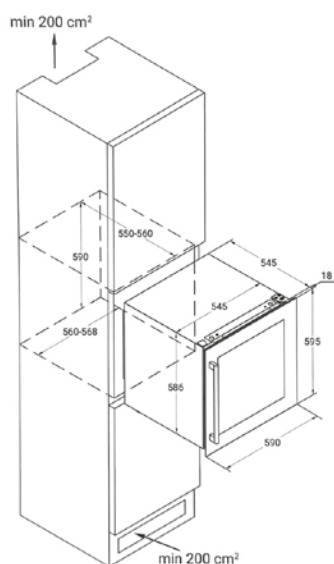

Dimensiones | Dimensions (AxFxA):  
545/590 x 545/563 x 586/595 mm

#### Características:

Integrables en columna de 60cm.  
Doble zona de temperatura con rango 5-22°C.  
Refrigeración por compresor antivibraciones.  
Baldas de madera extensibles.  
Puerta reversible de doble cristal con protección UV.  
Marco acero inox (X) - Cristal negro (B).

#### Characteristics:

Integrable in 60cm column.  
Double temperature zone with range 5-22°C  
Cooling by anti-vibration compressor.  
Wooden Retractable shelves.  
Reversible double glass door with UV protection.  
Stainless steel frame (X) - Black glass (B).

#### Caractéristiques:

Intégrable en colonne de 60cm.  
Zone de température double avec plage 5-22°C  
Refroidissement par compresseur anti-vibration.  
Étagères en bois extensibles.  
Porte double vitrée réversible avec protection UV.  
Cadre inox (X) - Verre noir (B).



# Vinoteca Libre Instalación W-1285

## Free Standing Wine Cellar W-1285

### Cave à Vin Autoportante W-1285

#### W-1285-X

REF: 07111404  
EAN: 8425131711144



#### W-1285-B

REF: 07111304  
EAN: 8425131711137

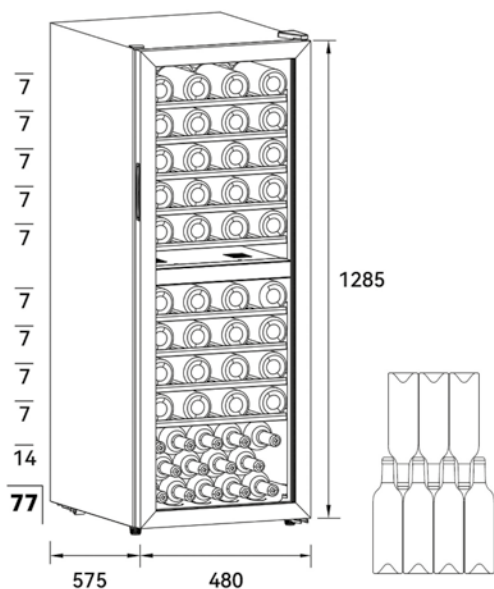

Dimensiones | Dimensions (AxFxX):  
575 x 480 x 1285 mm

#### Características:

Libre instalación de 1,285m.  
Doble zona de temperatura con rango 5-22°C.  
Refrigeración por compresor antivibraciones.  
Balda de madera extensible.  
Puerta reversible de doble cristal con protección UV.  
Marco acero inox (X) - Cristal negro (B).  
Pies ajustables.

#### Characteristics:

Free installation of 1,285m.  
Double temperature zone with range 5-22°C.  
Cooling by anti-vibration compressor.  
Wooden Retractable shelves.  
Reversible double glass door with UV protection.  
Stainless steel frame (X) - Black glass (B).  
Adjustable legs.

#### Caractéristiques:

Pose libre de 1,285m.  
Zone de température double avec plage 5-22°C.  
Refrigidissement par compresseur anti-vibration.  
Étagères en bois extensibles.  
Porte double vitrée réversible avec protection UV.  
Cadre inox (X) - Verre noir (B).  
Pieds réglables.



# Vinoteca Libre Instalación W-1770

## Free Standing Wine Cellar W-1770

### Cave à Vin Autoportante W-1770

**NEW**

#### W-1770-X

REF: 07113004  
EAN: 8425131711304



#### W-1770-B

REF: 07113104  
EAN: 8425131711311

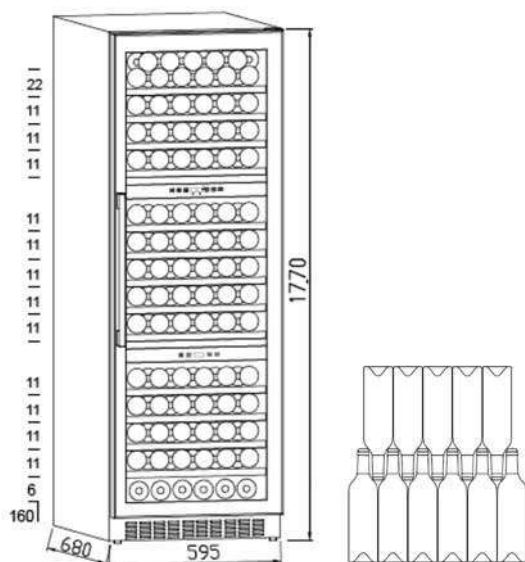

Dimensiones | Dimensions (AxFxA):  
595 x 680 x 1770 mm

#### Características:

Libre instalación de 1,77m.  
Triple zona de temperatura: arriba y abajo 12-22°C. Centro 5-12°C  
Refrigeración por compresor antivibraciones.  
Baldas de madera extensibles.  
Puerta reversible de doble cristal con protección UV.  
Marco acero inox (X) - Cristal negro (B).  
Pies ajustables.

#### Characteristics:

Free installation of 1,77m.  
Triple temperature zone: Up and down 12-22°C. Center 5-12°C  
Cooling by anti-vibration compressor.  
Wooden Retractable shelves.  
Reversible double glass door with UV protection.  
Stainless steel frame (X) - Black glass (B).  
Adjustable legs.

#### Caractéristiques:

Pose libre de 1,77m.  
Zone de température triple: Montée et descente 12-22°C. Centre 5-12°C  
Refrigeration par compresseur anti-vibration.  
Etagères en bois extensibles.  
Porte double vitrée réversible avec protection UV.  
Cadre inox (X) - Verre noir (B).  
Pieds réglables.





# Menaje

KITCHENWARE | MÉNAGE



# Batería de cocina PREMIUM

## PREMIUM cookware

### Batterie de cuisine PREMIUM

**Interior:**  
pulido espejo y bordes antiderrame.  
Espesor de 0,6mm.

**Inside:**  
mirror polished and antispill edges.  
Thickness of 0.6mm.

**À l'intérieur:**  
bords polis miroir et antidéversement.  
Épaisseur de 0,6 mm.

**Acabado:**  
satinado con decoración de anillo.

**Finish:**  
satin with ring decoration.

**Finition:**  
satinée avec décoration d'anneau.



**Asas extrafuertes:**  
con 10 puntos de soldadura.

**Extra strong handles:**  
with 10 welding points.

**Anses extra solides:**  
avec 10 points de soudure.

**Fondo:**  
difusor tricapa de 4mm para una distribución uniforme del calor.

**Base:**  
three layer heat diffuser for even heat distribution. 4 mm thick.

**Arrière-plan:**  
diffuseur tricouche de 4 mm pour une répartition homogène de la chaleur.



### Batería 9 piezas PREMIUM

Cookware 9 pieces

Batterie de cuisine 9 pièces



Incluye | Includes | Comprend:

04020504 + 04030004 + 04030104 + 04040604 + 04040704 +  
04040804 + 04040904 + 04041004 + 04044104



REF: 04000204  
EAN: 8425131400024



REF: 04001004  
EAN: 8425131400109

### Batería 5 piezas PREMIUM

Cookware 5 pieces

Batterie de cuisine 5 pièces

Incluye | Includes | Comprend:

04030104 + 04040704 + 04043704 + 04041004 + 04044104

### Batería 4 piezas PREMIUM

Cookware 4 pieces

Batterie de cuisine 4 pièces



REF: 04001104  
EAN: 8425131400116

Incluye | Includes | Comprend:

04043504 + 04040704 + 04040804 + 04043704

Cazo con tapa PREMIUM | Saucepan with lid | Casserole avec couvercle

REF:	Ø x H cm	L	EAN:	
04030104	16 x 7	1,4	8425131403018	4
04043604	20 x 10	3,1	8425131404374	4



Cazo sin tapa PREMIUM | Saucepan without lid | Casserole sans couvercle

REF:	Ø x H cm	L	EAN:	
04030004	14 x 9,5	1,5	8425131403001	4
04043504	20 x 8	2,5	8425131404367	4

Sartén PREMIUM | Sauté frying pan | Poêle Sauté

REF:	Ø x H cm	EAN:	
04020504	24 x 6	8425131402059	4



Cacerola con tapa PREMIUM | Pan with lid | Casserole avec couvercle

REF:	Ø x H cm	L	EAN:	
04040604	16 x 7	1,4	8425131404060	4
04040704	20 x 8	2,5	8425131404077	4
04040804	24 x 8,5	3,8	8425131404084	4
04043704	28 x 6,5	4	8425131404381	4
04043804	28 x 8	4,9	8425131404398	4
04043904	28 x 10	6,2	8425131404404	4

Olla con tapa PREMIUM | Pot with lid | Marmite avec couvercle

REF:	Ø x H cm	L	EAN:	
04040904	16 x 9	1,8	8425131404091	4
04041004	20 x 11	3,5	8425131404107	4
04044104	24 x 12	5,4	8425131404428	4
04044004	28 x 16	9,9	8425131404411	4



## Batería de cocina NEW CLASSIC

### NEW CLASSIC cookware

### Batterie de cuisine NEW CLASSIC

Tapa de vidrio ultraresistente:  
con orificio anticondensación.  
Ultra-resistant glass lid:  
with anti-condensation hole.  
Couvercle en verre ultra résistant:  
avec trou anti-condensation.

Asas y mangos:  
con 2 puntos de remache.  
Handle:  
2 rivet points  
Anses et poignées:  
avec 2 points de rivets.



Material:  
hierro fundido ligero de  
máxima calidad.

Material:  
top quality light cast iron.

Matériel:  
fonte légère de première qualité.

Recubrimiento antiadherente:  
ILAG.

Non-stick coating:  
ILAG.

Revêtement antiadhésif:  
ILAG.



### Batería de cocina 3 ollas NEW CLASSIC

Cookware 3 pots

Batterie de cuisine 3 casseroles

Incluye | Includes | Comprend:  
04040304 + 04040404 + 04040504



REF: 04000004  
EAN: 8425131400000



REF: 04000104  
EAN: 8425131400017

### Batería de cocina 4 sartenes NEW CLASSIC

Cookware 4 frying pans

Batterie de cuisine 4 poêles

Incluye | Includes | Comprend:  
04020401 + 04020301 + 04020201 + 04050004

### Batería de cocina 2 ollas + 1 sartén NEW CLASSIC

Cookware 2 pots + 1 frying pan

Batterie de cuisine 2 casseroles + 1 poêle

Incluye | Includes | Comprend:  
04040504 + 04040304 + 04040404



REF: 04000804  
EAN: 8425131400086



Sartén NEW CLASSIC | Frying pan | Poêle

REF:	Ø x H cm	EAN:	
04020201	20 x 4,4	8425131432025	6
04020301	24 x 4,4	8425131432032	6
04023301	26 x 5	8425131432339	6
04020401	28 x 5,4	8425131432049	6



Sartén con asa NEW CLASSIC | Frying pan with handle | Poêle avec poignée

REF:	Ø x H cm	EAN:	
04023401	30 x 5,4	8425131402455	6



Paella NEW CLASSIC | Paella pan | Paella poêle

REF:	Ø x H cm	EAN:	
04050001	30 x 3,5	8425131405005	4



Olla Holandesa Tapa | Dutch oven with lid | Marmite hollandaise avec couvercle

REF:	Ø x H cm	L	EAN:	
04040304	24 x 11	3,4	8425131404039	4

Cacerola con tapa | Casserole pan with lid | Casserole avec couvercle

REF:	Ø x H cm	L	EAN:	
04040404	26 x 13	2,6	8425131040404	4
04040504	28 x 13	3,1	8425131404053	4



Olla con tapa NEW CLASSIC | Pot with lid | Marmite avec couvercle

REF:	Ø x H cm	L	EAN:	
04043304	28 x 9,5	3,6	8425131404343	4
04043404	32 x 10,5	5,6	8425131404350	4

# Sartenes PREMIUM COAT

## PREMIUM COAT frying pans

### Poêles PREMIUM COAT



#### Sartén PREMIUM COAT | Frying pan | Poêle

REF:	Ø x H cm	EAN:	🏷️
04024601	18 x 5	8425131402462	6 <b>NEW</b>
04023801	20 x 5	8425131423801	6
04024701	22 x 5	8425131402479	6 <b>NEW</b>
04023901	24 x 5	8425131423900	6
04024001	26 x 5	8425131424006	6
04023501	28 x 5	8425131402448	6



#### Sartén con asa PREMIUM COAT | Frying pan with handle | Poêle avec anse

REF:	Ø x H cm	EAN:	🏷️
04024101	32 x 6	8425131402424	6

#### Sartén con grill PREMIUM COAT | Grill frying pan | Poêle avec grill

REF:	cm	EAN:	🏷️
04024201	28 x 28 x 5	8425131424204	6





# Olla a Presión CLASSIC

## CLASSIC Pressure Cooker

### Autocuiseur CLASSIC

**Triple sistema de seguridad:**  
válvula giratoria, válvula depresora  
y barra de cierre de seguridad.

**Triple security system:**  
rotary valve, depressor valve and  
safety closing bar.

**Triple système de sécurité:**  
soupape rotative, vanne dépresseur  
et barre de fermeture de sécurité.



**Asas y Pomo:**  
de material termostensible. Asas  
cortas para fácil almacenamiento.

**Handles and Knob:**  
of heat-resistant material. Short  
handles for easy storage.

**Anses et pommeau:**  
en matériau résistant à la chaleur.  
Poignées courtes pour rangement  
facile.

**Fondo:**  
difusor tri-capa de 6 mm.

**Base:**  
three layer heat diffuser for even  
heat distribution. 6 mm thick.

**Arrière-plan:**  
diffuseur tricouche de 6 mm.

**Cuerpo:**  
espesor de 1mm.

**Body:**  
1mm thick.

**Corps:**  
épaisseur 1 mm.



#### Olla a Presión CLASSIC | Pressure cooker | Autocuiseur

REF:	Ø x H cm	L	EAN:	
04010204	24,5 x 20	4,5	8425131401021	2
04010104	24,5 x 23	6	8425131401014	2
04010004	24,5 x 30	8	8425131401007	2
04010804	28 x 20	10	8425131401083	2
04010904	28 x 23	12	8425131401090	2
04011004	28 x 30	16	8425131401106	2



#### REPUESTOS Olla a Presión CLASSIC | SPARE PARTS | DES PIÉCES DÉTACHÉES.

	REF:	EAN:	Blister
Asas   Handles   Anses CLASSIC	44106901	8425131106902	
Válvula   Valve   Soupape CLASSIC	44107001	8425131107008	
Pomo   Knob   Pommeau CLASSIC	44107201	8425131107206	
Goma silicona   Silicone gasket   Joint Silicone 4,5L - 6L - 8L CLASSIC ø 24,5 cm	44106801	8425131106803	
Goma silicona   Silicone gasket   Joint Silicone 10L - 12L - 16L CLASSIC ø 28 cm	44107301	8425131107305	

# Olla Rápida a Presión LIGHTNING 2,7L

## 2,7L LIGHTNING Rapid Pressure Cooker

### Autocuiseur Rapide LIGHTNING 2,7L



#### Olla Rápida a Presión LIGHTNING | Pressure cooker | Autocuiseur

REF:	Ø cm	L	EAN:	
04011204	17	2,7	8425131401137	6



#### REPUESTOS Olla a Presión Rápida LIGHTNING | SPARE PARTS | PIÉCES DÉTACHÉES. 2,7L - ø17cm

	REF:	EAN:	Blister
Goma silicona   Silicone gasket   Joint Silicone LIGHTNING 2,7L - Ø 17 cm	44102501	8425131441256	
Mango corto inferior   Lower short handle   Poignée courte inférieure LIGHTNING 2,7L	44105901	8425131059048	
Mango corto superior   Upper short handle   Poignée courte supérieure LIGHTNING 2,7L	44105801	8425131058041	
Mango largo inferior   Long lower handle   Poignée longue inférieure LIGHTNING 2,7L	44105701	8425131057044	
Mango largo superior   Upper long handle   Poignée longue supérieure LIGHTNING 2,7L	44105601	8425131056047	
Válvula   Valve   Soupape LIGHTNING 2,7L	44106101	8425131061041	

# Olla Rápida a Presión LIGHTNING 4-6L

## 4-6L LIGHTNING Rapid Pressure Cooker

### Autocuiseur Rapide LIGHTNING 4-6L

**Triple Sistema de Seguridad:**  
válvula giratoria, válvula depresora y cierre de seguridad.

**Triple Security System:**  
rotary valve, depressor valve and safety lock closure.

**Triple système de sécurité:**  
vanne rotative, vanne dépresseur et fermeture à verrouillage de sécurité.

**2 Niveles de Presión.**  
Bloqueo automático de apertura.

**2 Pressure Levels.**  
Automatic opening lock.

**2 niveaux de pression.**  
Verrouillage d'ouverture automatique.

**Asas y Mango:** ergonómicos de baquelita termoresistente.

**Handles:** ergonomic heat-resistant bakelite.

**Poignées:** Bakélite ergonomique résistante à la chaleur.

**Fondo:**  
espesor de 5,5 mm.

**Base:**  
5,5mm thick.

**Arrière-plan:**  
5,5mm d'épaisseur.

**Cestillo Inox. perforado:**  
permite la cocción vapor (4-6-4+6L).

**Stainless steel basket perforated:**  
allows steam cooking (4-6-4+6L).

**Panier en acier inoxydable perforé:**  
permet une cuisson vapeur (4-6-4+6L).



#### Olla Rápida a Presión LIGHTNING | Pressure cooker | Autocuiseur

REF:	Ø	L	EAN:	
04010504	22	4	8425131401953	2
04010404	22	6	8425131401045	2
04011104	22	SET 4 + 6L	8425131401120	2



#### REPUESTOS Olla a Presión Rápida LIGHTNING | SPARE PARTS | PIÉCES DÉTACHÉES. 4 + 6L - Ø22cm

	REF:	EAN:	 Blister
Goma silicona   Silicone gasket   Joint Silicone LIGHTNING 4+6L - Ø 22 cm	44102301	8425131441232	
Mango largo inferior   Long lower handle   Poignée longue inférieure LIGHTNING 4+6L	44105201	8425131052049	
Mango largo superior   Upper long handle   Poignée longue supérieure LIGHTNING 4+6L	44105301	8425131053046	
Asa   Handle   Anse LIGHTNING 4+6L	44105501	8425131155047	
Válvula   Valve   Soupape LIGHTNING 4 + 6L	44106001	8425131060044	

# Olla Rápida a Presión HORIZON

## HORIZON Rapid Pressure Cooker

### Autocuiseur Rapide HORIZON

**“Easy System”**  
Apertura y cierre en cualquier posición.  
Opening and closing in any position.  
Ouverture et fermeture dans n'importe quelle position.

**Triple Sistema de Seguridad:**  
válvula giratoria, válvula depresora y cierre de seguridad.

**Triple Security System:**  
rotary valve, depressor valve and safety lock closure.

**Triple système de sécurité:**  
vanne rotative, vanne dépresseur et fermeture à verrouillage de sécurité.

**2 Niveles de Presión.**  
**Bloqueo automático de apertura.**

**2 Pressure Levels.**  
**Automatic opening lock.**

**2 niveaux de pression.**  
**Verrouillage d'ouverture automatique.**

**Asas:**  
ergonómicas y cortas  
para fácil almacenaje.

**Handles:**  
ergonomic and short  
for easy storage.

**Anses:**  
ergonomiques et courtes  
pour un rangement facile.

**Fondo:**  
espesor de 5 mm (4L & 8L), 6mm (12L).

**Base:**  
5 mm (4L & 8L), 6mm (12L) thick.

**Arrière-plan:**  
5 mm (4L & 8L), 6mm (12L) d'épaisseur.

**Cuerpo:**  
espesor de 1mm.

**Body:**  
1mm thick.

**Corps:**  
épaisseur 1 mm.



#### Olla Rápida a Presión HORIZON | Pressure cooker | Autocuiseur

REF:	Ø cm	L	EAN:		
04011904	22	4	8425131401199	2	<b>NEW</b>
04011704	24	8	8425131401175	2	
04012004	28	12	8425131401205	2	<b>NEW</b>



Cestillo en acero inoxidable incluido en los 3 tamaños | Stainless steel steam rack included in all 3 sizes | Panier en acier inoxydable inclus dans les 3 tailles

#### REPUESTOS Olla a Presión Rápida HORIZON | SPARE PARTS | PIÈCES DÉTACHÉES.

	REF:	EAN:	
Goma silicona   Silicone gasket   Joint silicone HORIZON 4L - Ø 22 cm	44107701	8425131107701	
Goma silicona   Silicone gasket   Joint silicone HORIZON 8L - Ø 24 cm	44107401	8425131107404	
Goma silicona   Silicone gasket   Joint silicone HORIZON 12L - Ø 28 cm	44107801	8425131107800	
Asa   Handle   Anse HORIZON	44107501	8425131107503	
Válvula   Valve   Soupape HORIZON	44107601	8425131107602	

# Pequeño Menaje

SMALL KITCHENWARE | PETIT MÉNAGE







## Cafetera italiana HOLA Roja

HOLA moka coffee maker Red

Cafetière moka HOLA Rouge



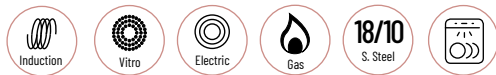

REF:	Ø x Hcm		EAN:	
01602004	10 x 17,5	4	8425131160201	12
01602104	11 x 19,5	6	8425131160218	12
01602204	12,5 x 21,5	9	8425131160225	12



## Cafetera italiana HOLA Blanca

HOLA moka coffee maker White

Cafetière moka HOLA Blanche



REF:	Ø x Hcm		EAN:	
01602304	10 x 19	6	8425131160232	12
01602404	11 x 22	9	8425131160249	12
01602504	12,5 x 24,5	12	8425131160256	12



## Cafetera italiana HOLA Plateada

HOLA moka coffee maker Plated

Cafetière moka HOLA Argentée

REF:	Ø x Hcm		EAN:	
01602604	10 x 17,5	6	8425131160263	12
01602704	11 x 19,5	9	8425131160270	12
01602804	12,5 x 21,5	12	8425131160287	12





## Cafetera Italiana ALONDRA

ALONDRA moka coffee maker

Cafetière moka ALONDRA



REF:	Ø x Hcm		EAN:	
01601104	11,2 x 1 3,5	6	8425131160119	12
01601204	12,3 x 21,5	9	8425131160126	12
01601304	16,5 x 26	12	8425131160133	12



## Termo Servidor

Server Thermo

Pichet Isotherme

REF:	Ø x Hcm	L	EAN:	
01220504	15,50 x 21	1	8425131122056	12
01220804	16 x 22,85	2	8425131122087	12



## Termo

Thermo

Bouteille Isotherme

REF:	Ø x Hcm	ml	EAN:	
01220304	7 x 19	350	8425131122032	12
01220104	7 x 24,50	500	8425131122018	12
01220204	8,50 x 31	1000	8425131122025	12



# Jamonero PRO

## Ham holder PRO

### Porte-jambon PRO

NEW



**Casquillo giratorio:**  
acero laminado con lacado térmico.

**Rotating bushing:**  
laminated steel with thermal lacquer.

**Douille tournante:**  
acier laminé avec laque thermique.

**Apoyo central basculante:**  
con 2 puntos de agarre a la base.

**Tilting central support:**  
with 2 attachment points to the base.

**Support central inclinable:**  
avec 2 points de fixation à la base.

**Soporte:**  
en fibra de madera hidrófuga.  
Pies de silicona antideslizantes.

**Supporting base:**  
in water-repellent wood fiber.  
Non slippery silicone feet.

**Support:**  
en fibre de bois hydrofuge.  
Pieds en silicone antidérapants.

**Uso:**  
profesional y doméstico. Apto para jamones y paletas.

**Use:**  
professional and domestic. Suitable for hams and shoulders.

**Usage:**  
professionnel et domestique. Convient aux jambons et aux épaules.

**Dimensiones y peso:**  
**Dimensions and weight:**  
**Dimensions et poids:**  
51,5 x 21,5 x 38cm | 6,45kg.

REF: 02200104    EAN: 8425131220011    1



# Jamonero GOURMET

## Ham holder GOURMET

### Porte-jambon GOURMET

NEW



**Firmeza:**  
fijación de acero inoxidable firme y estable.

**Firmness:**  
Firm and stable stainless steel fixation.

**Fermeté:**  
Fixation ferme et stable en acier inoxydable.

**Soporte:**  
doble lacado ecológico en fibra de madera hidrófuga. Pies de silicona antideslizantes.

**Medium:**  
double ecological lacquer in wood fiber water-repellent. Non-slip silicone feet.

**Support:**  
double laque écologique en fibre de bois hydrofuge. Pieds en silicone antidérapants.

**Uso:**  
profesional y doméstico. Apto para jamones y paletas.

**Use:**  
professional and domestic. Suitable for hams and shoulders.

**Usage:**  
professionnel et domestique. Convient aux jambons et aux épaules.

**Dimensiones y peso:**  
**Dimensions and weight:**  
**Dimensions et poids:**  
49,5 x 19,5 x 24,5cm | 3,5kg.

REF: 02200004    EAN: 8425131220004    1



## Utensilios de Cocina

### Kitchen utensils

### Ustensiles de cuisine

Cuchillo deshuesador  
Boning knife  
Couteau à désosser



11 cm  
REF: 01820501  
EAN: 8425131182050

14 cm  
REF: 01819101  
EAN: 8425131181916

Cuchillo jamonero  
Ham knife  
Couteau à jambon



21 cm  
REF: 01819201  
EAN: 8425131181923

26 cm  
REF: 01820601  
EAN: 8425131182067

Cuchillo para fiambres 21 cm  
Cold cuts knife 21 cm  
Couteau charcuterie 21 cm



REF: 01818801  
EAN: 8425131181886

Cuchillo patatero 8,5 cm  
Potato knife 8,5 cm  
Couteau à pommes de terre 8,5 cm



REF: 01818001  
EAN: 8425131181800

Cuchillo de pan 21 cm  
Bread knife 21 cm  
Couteau à pain 21 cm



REF: 01818901  
EAN: 8425131181893

Afilador de cuchillos  
Knife sharpener  
Aiguiseur de couteaux



REF: 01212601  
EAN: 8425131121264

Tenedor trinchante 14 cm  
Carving fork 14 cm  
Fourchette de chef 14 cm



REF: 01819701  
EAN: 8425131181978

Taco de cuchillos 6 piezas

Knife block 6 pieces

Bloc couteaux 6 pièces



Incluye | Includes | Comprend:

01818101 | 01819101 | 01818401 | 01819201 | 01819401 | 01819901



REF: 01820405

EAN: 8425131182043

Organizador de cuchillos para cajón 5 piezas

Knife organizer for drawer 5 pieces

Organisateur de couteaux pour tiroir 5 pièces



Incluye | Includes | Comprend:

01818201 (x3) | 01819401 | 01818901



REF: 01821604

EAN: 8425131182166

Organizador de cuchillos para cajón 11 piezas

Knife organizer for drawer 11 pieces

Organisateur de couteaux pour tiroir 11 pièces



Incluye | Includes | Comprend:

01818201 (x6) | 01819401 | 01819601 | 01818901 | 01819201 | 01819101



REF: 01821704

EAN: 8425131182173

Cuchillo de cocina  
Kitchen knife 10 cm  
Couteau de cuisine 10 cm

10 cm  
REF: 01818101  
EAN: 8425131181817

12 cm  
REF: 01818201  
EAN: 8425131181824

14 cm  
REF: 01818301  
EAN: 8425131181831

16 cm  
REF: 01818401  
EAN: 8425131181848

18 cm  
REF: 01818501  
EAN: 8425131181855

21 cm  
REF: 01818601  
EAN: 8425131181862

26 cm  
REF: 01818701  
EAN: 8425131181879



Cuchillo de chef  
Chef knife  
Couteau de chef

21 cm  
REF: 01819401  
EAN: 8425131181947

25 cm  
REF: 01819601  
EAN: 8425131181961

30 cm  
REF: 01820001  
EAN: 8425131182005



Macheta 18 x 8,6 cm. (487gr.)  
Cleaver 18 x 8,6 cm  
Couperet 18 x 8,6 cm



REF: 01821201  
EAN: 8425131182128

Chaira 23 cm  
Sharpening steel 23 cm  
Fusil à aiguiser 23 cm



REF: 01819901  
EAN: 8425131181992

**Pinza de cocina 35 cm. Acero cromado**  
 Kitchen tong 35 cm. Chrome steel  
 Pince de cuisine 35 cm. Acier chromé



REF: 01210301  
 EAN: 8425131121035

**Pinza de cocina 55 cm. Inox**  
 Kitchen tong 55 cm. Inox  
 Pince de cuisine 55 cm. Inox



REF: 01210801  
 EAN: 8425131121080

**Pinza para cocina 43 cm. Silicona**  
 Kitchen tong 43 cm. Silicone  
 Pince de cuisine 43 cm. Silicone



REF: 01905001  
 EAN: 8425131190505

**Pinza para cocina 27 cm. Silicona**  
 Kitchen tong 27 cm. Silicone  
 Pince de cuisine 27 cm. Silicone

**NEW**



REF: 01905101  
 EAN: 8425131190512

**Pinza multiusos 20 cm. Inox**  
 Multipurpose tong 20cm. Inox  
 Pince multi-usage 20cm. Inox



REF: 01316301  
 EAN: 8425131131638

**Pinza multiusos 27,5cm. Inox**  
 Multipurpose tong 27,5cm. Inox  
 Pince multi-usage 27,5cm. Inox



REF: 01316101  
 EAN: 8425131131614

Pinza para servicio de mesa 20 cm. Inox  
Serving tong 20 cm. Inox  
Pince de service 20 cm. Inox



REF: 01314901  
EAN: 8425131131492

Pinza para espaguetis y carne 20 cm  
Spaghetti and meat tong 20 cm  
Pince à spaghettis et viande 20 cm



REF: 01316001  
EAN: 8425131131654

Pinzas de chef  
Chef tongs  
Pincés de chef



10 cm.  
REF: 01211201  
EAN: 8425131121127



12,5 cm.  
REF: 01211501  
EAN: 8425131121158



15,5 cm.  
REF: 01210901  
EAN: 8425131121097

Abrelatas tenaza. Cromado  
Pincer can opener. Chrome-plated  
Ouvre-boîte à tenaille. Chromé



REF: 00110001  
EAN: 8425131011008

Abrelatas mariposa cromado con descapsulador  
Butterfly can opener chrome-plated with bottle opener  
Ouvre-boîte papillon chromé avec décapsuleur



REF: 021010801  
EAN: 8425131211088

Abrelatas montañero. Niquelado  
Country can opener. Nickel-plated  
Ouvre-boîte de poche. Nickelé



REF: 00110501  
EAN: 8425131011053

Abrelatas montañero. Pavonado  
Country can opener. Bronzed  
Ouvre-boîte de poche. Bleu



REF: 00111201  
EAN: 8425131011121

Abrelatas Papillón. Rojo  
Papillon can opener. Red  
Ouvre-boîte Papillon. Rouge



REF: 00111001  
EAN: 8425131011107

Rompemarisco tenaza. Acero inoxidable  
Sea food cracker. Stainless steel  
Pince à crustacés. Acier inoxydable

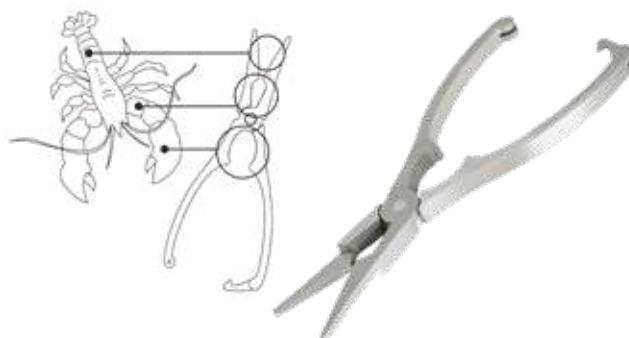

REF: 00881501  
EAN: 8425131088154

Tijeras de cocina 21 cm / 2,5 mm  
Kitchen scissors 21 cm / 2,5 mm  
Ciseaux de cuisine 21 cm / 2,5 mm



REF: 01200201  
EAN: 8425131120021

Tijeras profesionales  
Professional scissors  
Ciseaux professionnels

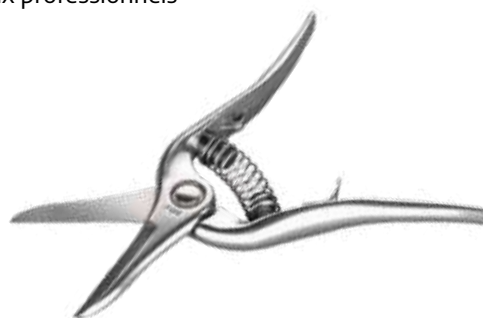

REF: 01200401  
EAN: 8425131120045

Tijeras 5 filos  
5 blade scissors  
Ciseaux 5 lames



REF: 01200501  
EAN: 8425131120052

Descamador. Inox  
Fish scraper. Inox  
Écailleur. Inox



REF: 01314501  
EAN: 8425131131454

Cascanueces. Acero forjado pulido y cromado  
Nutcracker. Steel forged polished and chromed  
Casse-noix. Acier forgé poli et chromé



REF: 00880101  
EAN: 8425131088017

Cascanueces. Acero estampado cromado  
Nutcracker. Chrome-plated stamped steel  
Casse-noix. Acier embouti chromé



REF: 00880001  
EAN: 8425131088000

Salvamantel Extensible 15 x 15 cm. Cromado  
Extensible Table mat 15 x 15 cm. Chrome-plated  
Dessous de plat Extensible 15 x 15 cm. Chromé

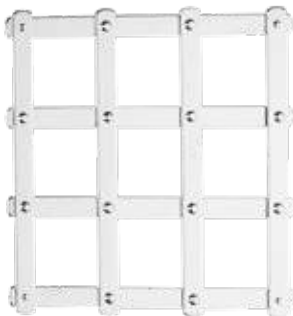

REF: 01111002  
EAN: 8425131111104

Salvamantel Extensible 27 x 26 cm. Cromado  
Extensible Table mat 27 x 26 cm. Chrome-plated  
Dessous de plat Extensible 27 x 26 cm. Chromé

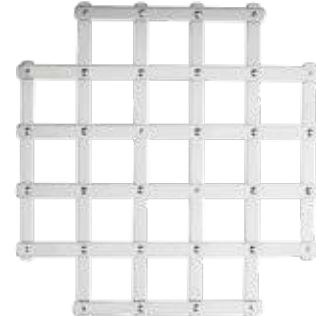

REF: 01111102  
EAN: 8425131111111

Mortero ø 12 cm. Inox (0,52kg)

Mortar ø 12 cm. Inox (0,52kg)

Mortier ø 12 cm. Inox (0,52kg)



REF: 01218004  
EAN: 8425131121806

Corta pizza 10 cm. Inox

Pizza cutter 10 cm. Inox

Roulette à pizza 10 cm. Inox



REF: 021120301  
EAN: 8425131212030

Pelapatatas. Inox

Potato peeler. Inox

Éplucheur. Inox



REF: 021071001  
EAN: 8425131217103

Pelapatatas Y. Inox

Y Flat potato peeler. Inox

Éplucheur plat Y. Inox

**NEW**



REF: 01320001  
EAN: 8425131132000

Descorazonador de manzanas. Inox

Apple corer. Inox

Vide-pommes. Inox



REF: 021120201  
EAN: 8425131212023

Moldeador de patatas doble ø 27-31 mm. Inox

Double potato moulder ø 27-31 mm. Inox

Cuillère parisienne ø 27-31 mm. Inox



REF: 021121201  
EAN: 8425131212122

Rallador 6 lados - 24cm. Inox  
Grater 6 sides - 24cm. Inox  
Râpe 6 faces - 24cm. Inox



REF: 021121602  
EAN: 842513121217

Rallador 4 lados - 24cm. Inox  
Grater 4 sides - 24cm. Inox  
Râpe 4 faces - 24cm. Inox



REF: 021121702  
EAN: 8425131212177

Lira. Inox  
Cheese cutter. Inox  
Lyre à fromage. Inox

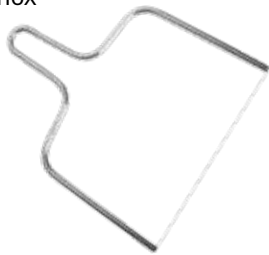

12 cm  
REF: 023001202  
EAN: 8425131230126



17 cm  
REF: 023001702  
EAN: 8425131230171



21 cm  
REF: 023002102  
EAN: 8425131230218

10 Hilos para lira  
10 Spare wires for cheese cutter  
10 Fils pour lyre



12 cm  
REF: 023011202  
EAN: 8425131231123



17 cm  
REF: 023011702  
EAN: 8425131231178



21 cm  
REF: 023012102  
EAN: 8425131231215

Calzador con gancho  
Shoehorn with hook  
Chausse-pieds avec crochet



11,5 cm  
REF: 00220101  
EAN: 8425131022011



42 cm  
REF: 00220502  
EAN: 8425131022059

# Minidomésticos

SMALL APPLIANCES | PETIT ÉLECTROMÉNAGER





# Cafetera Espresso/Capuchino ALBA

## Espresso/Capuccino Machine ALBA

### Machine à Espresso/Capuccino ALBA

NEW



**Control digital integrado:**  
sencilla selección de funciones y personalización de tu café.

**Integrated digital control:**  
easy selection of functions and personalization of your coffee.

**Commande numérique intégrée:**  
por une sélection facile des fonctions et une personnalisation de votre café.

**Apagado automático:**  
para una mayor seguridad y ahorro de energía.

**Auto power off:**  
for greater security and energy saving.

**Mise hors tension automatique:**  
pour plus de sécurité et les économies d'énergie.

**20 bares de presión:**  
Consigue el mejor café espresso en cada taza.

**20 bars pressure:**  
get the best coffee espresso in every cup.

**Pression 20 bars:**  
obtenez le meilleur café expresso dans chaque tasse.

**Bandeja extraíble:**  
de acero inoxidable para una fácil limpieza.

**Removable tray:**  
stainless steel for easy cleaning.

**Plateau amovible:**  
acier inoxydable pour un nettoyage facile.

**Vaporizador:**  
para espumar leche, calentar líquidos, preparar infusiones y los mejores capuccinos.

**Steamer:**  
to froth milk, heat liquids, prepare infusions and the best cappuccinos.

**Cuiseur vapeur:**  
pour faire mousser le lait, chauffer des liquides, préparer des infusions et les meilleurs cappuccinos.

**Depósito de agua extraíble**  
de 1,2L de capacidad.

**Removable water tank**  
1.2L capacity.

**Réservoir d'eau amovible**  
capacité de 1,2 L.

**Sistema de calentamiento Thermoblock:**  
calienta el agua en 30".

**Heating system Thermoblock:**  
heat the water in 30".

**Système de chauffage Thermoblock:**  
faites chauffer l'eau en 30".

**Compatibilidad:**  
apta para café molido y cápsulas ESE.

**Compatibility:**  
suitable for ground coffee and ESE capsules.

**Compatibilité:**  
convient au café moulu et aux capsules ESE.

REF: 05203804  
EAN: 8425131520388



2



# Cafetera Italiana Eléctrica

## Electric Moka Coffee Maker

### Cafetière Moka Électrique

**Interior:**  
de aluminio.

**Inside:**  
of aluminum.

**À l'intérieur:**  
d'aluminium.



**Base:**  
desmontable  
con 360° de rotación.

**Base:**  
removable  
with 360° rotation.

**Base:**  
amovible  
avec rotation à 360°.



**Asa ergonómica:**  
permite un agarre firme,  
cómodo y seguro.

**Ergonomic handle:**  
allows a firm grip,  
comfortable and safe.

**Anse ergonomique:**  
permet une prise ferme,  
confortable et sûr.

**Mecanismo:**  
luz de encendido y función "mantener  
caliente".

**Mechanism:**  
power indicator light and "keep warm"  
function.

**Mécanisme:**  
voyant d'alimentation et fonction  
"maintien au chaud".

REF:



EAN:



05203204

6

8425131520326

8



# Molinillo para café y especias CG-30

## Coffee and spice Grinder CG-30

### Moulin à café et épices CG-30

**Cuchilla:**  
de acero inoxidable  
de larga duración.

**Blade:**  
long-lasting stainless steel.

**Lame:**  
acier inoxydable longue durée.

**Cuerpo:**  
de acero inoxidable cepillado.

**Body:**  
brushed stainless steel.

**Corps:**  
acier inoxydable brossé.



**Tapa:**  
transparente con bloqueo de seguridad.

**Top:**  
transparent with safety lock.

**Couvercle:**  
transparent avec blocage de sécurité.

**Recipiente:**  
extraíble para facilitar la recogida.

**Bowl:**  
Removable for easy collection.

**Récipient:**  
Amovible pour une collecte facile.

**Muele:**  
granos de café, frutos secos y especias.

**Grinds:**  
coffee beans, nuts and spices.

**Moutures:**  
grains de café, noix et épices.

REF:

EAN:



05210004

8425131521002

12



# Cafetera Portátil GIRO

## GIRO Portable Coffee Maker

### Cafetière Portable GIRO

**NEW**



**Incluye:**  
cable USB.  
**Includes:**  
USB wire.  
**Comprend:**  
cable USB.



**Interior:**  
de acero inoxidable.  
**Inner:**  
stainless steel.  
**À l'intérieur:**  
acier inoxydable.



**Batería:**  
con indicador luminoso de carga,  
prepara hasta 30 tazas de café.  
**Battery:**  
with charging indicator light,  
prepares up to 30 cups of coffee.  
**Batterie:**  
avec voyant de charge,  
prépare jusqu'à 30 tasses de café.



**Calentamiento rápido:**  
prepara el café en 3-4 minutos.  
**Fast heating:**  
prepares coffee in 3-4 minutes.  
**Chauffage rapide:**  
prépare le café en 3-4 minutes.



**Compatible:**  
con cápsulas y café molido.  
**Compatible:**  
with capsules and ground coffee.  
**Compatible:**  
avec capsules et café moulu.



**Doble función:**  
prepara café frío y caliente.  
**Dual function:**  
prepares hot and cold coffee.  
**Double fonction:**  
prépare du café chaud et froid.

Blanca | White | Blanc

REF: 05204604  
EAN: 8425131520463  
20



Negra | Black | Noir

REF: 05204504  
EAN: 8425131520456  
20

## Tostadora Plana FT- 600

### Flat Toaster FT- 600

### Grille-Pain Plat FT- 600

**Carcasa:**  
antiquemaduras, tacto frío.

**Case:**  
antiscald, cool touch.

**Châssis:**  
anti-brûlure, toucher froid.

**Bandeja de migas extraíble:**  
para una fácil limpieza.

**Removable crumb tray:**  
for easy cleaning.

**Plateau ramasse-miettes amovible:**  
pour un nettoyage facile.



**Capacidad:**  
para 4 rebanadas (24x18,5cm).

**Capacity:**  
for 4 slices (24x18.5cm).

**Capacité:**  
pour 4 tranches (24x18,5cm).

**Mandos:**  
6 niveles de tostado, parada automática con aviso sonoro.

**Controls:**  
6 toasting levels, automatic stop with audible warning.

**Contrôles:**  
6 niveaux de grillage, arrêt automatique avec avertissement sonore.

**Temporizador:**  
mecánico variable.

**Timer:**  
variable mechanic.

**Minuteur:**  
mécanique réglable.

REF:

EAN:



05230304

8425131523037

8



## Tostadora Ranura Ancha T-1000

### Wide Slot Toaster T-1000

### Grille-pain Large Fente T-1000

**Bandeja de migas extraíble:**

para una fácil limpieza.

**Removable crumb tray:**  
for easy cleaning.

**Plateau ramasse-miettes amovible:**  
pour un nettoyage facile.

**Base:**  
con recogecables.

**Base:**  
with cable tie.

**Base:**  
avec serre-câble.



**Ranura:**  
larga y extraancha (3cm) para 2 tostadas.

**Slot:**  
long and extra wide (3cm) for 2 toasts.

**Fente:**  
long et extra large (3 cm) pour 2 toasts.

**Funciones:**  
7 niveles de tostado, recalentar, descongelar y detener.

**Features:**  
7 levels of toasting, reheat, defrost and stop.

**Fonctions:**  
7 niveaux de grillage, réchauffage, décongélation et arrêt.

REF:

EAN:



05230004

8425131523006

4



NEW

# Tostadora Ranura Ancha T-1001

## Wide Slot Toaster T-1001

### Grille-pain Large Fente T-1001

**Ranura:**  
larga y extra ancha (4cm) para 2 tostadas.

**Slot:**  
long and extra wide (4cm) for 2 toasts.

**Fente:**  
longue et extra large (4 cm) pour 2 toasts.

**Función antiatasco:**  
expulsión manual con desconexión.

**Antijam function:**  
manual ejection with disconnection.

**Fonction antibourrage:**  
éjection manuelle avec déconnexion.



**Bandeja de migas extraíble:**  
para una fácil limpieza.

**Removable crumb tray:**  
for easy cleaning.

**Plateau ramasse-miettes amovible:**  
pour un nettoyage facile.

**Base:**  
antideslizante y hueco recogecables.

**Base:**  
non-slip and cable collection hole.

**Base:**  
antidérapant et trou de collecte des câbles.

**Funciones:**  
7 niveles de tostado, recalentar, descongelar y detener.

**Features:**  
7 levels of toasting, reheat, defrost and stop.

**Fonctions:**  
7 niveaux de grillage, réchauffage, décongélation et arrêt.



**Pantalla:**  
digital y control de tiempo variable.

**Screen:**  
digital and variable time control.

**Écran:**  
contrôle du temps numérique et variable.

REF: 05230404  
EAN: 8425131523044  
4



## Exprimidor con Palanca JE-101X Juice extractor with Lever JE-101X Presse-agrumes à Levier JE-101X

**Sistema:**  
de extracción continua.  
Apto para uso intensivo.

**System:**  
of continuous extraction.  
Suitable for intensive use.

**Système:**  
d'extraction continue.  
Convient pour un usage intensif.

**Base:**  
antideslizante.

**Base:**  
non-slip.

**Base:**  
antidérapant.



**Palanca ergonómica:**  
en aluminio, ayuda la extracción.

**Ergonomic lever:**  
in aluminum, helps extraction.

**Levier ergonomique:**  
en aluminium, facilite l'extraction.

**Filtro para pulpa:**  
de acero inoxidable.

**Pulp filter:**  
stainless steel.

**Filtre à pulpe:**  
acier inoxydable.

**Cuerpo:**  
de acero inoxidable.

**Body:**  
stainless steel.

**Corps:**  
acier inoxydable.

REF: 05240204      EAN: 8425131524027       4



## Hervidor de agua KT-1700X Kettle KT-1700X Bouilloire KT-1700X

**Jarra graduada:**  
de cristal y acero inoxidable.

**Graduated jug:**  
glass and stainless steel.

**Récipient gradué:**  
verre et acier inoxydable.

**Base:**  
antideslizante y hueco recogecables.

**Base:**  
non-slip and cable collection hole.

**Base:**  
antidérapant et trou de collecte des câbles.



**Tapa:**  
apertura automática.

**Top:**  
automatic opening.

**Couvercle:**  
ouverture automatique.



**Pantalla Led:**  
programador de tiempo y función mantenimiento temperatura.

**Led screen:**  
time programmer and temperature maintenance function.

**Écran Led:**  
programmeur de temps et fonction maintien de la température.

**Temperatura:**  
rango 40°-100°c (ajustable en 5°c).

**Temperature:**  
range 40°-100°c (adjustable by 5°c).

**Température:**  
plage 40°-100°c (réglable de 5°c).

REF: 05250104      EAN: 8425131525017       6



## Barbacoa Grill BBC-1800

### Grill Barbecue BBC-1800

### Grill Barbecue BBC-1800

**Tapa:**  
de vidrio, desmontable.

**Top:**  
glass, removable.

**Couvercle:**  
verre, amovible.

**Bandeja extraíble:**  
recoge grasas.

**Removable tray:**  
collects fats.

**Plateau amovible:**  
recueille les graisses.



**Temperatura:**  
regulador con 5 niveles.

**Temperature:**  
regulator with 5 levels.

**Température:**  
régulateur à 5 niveaux.

**Placa (35 x 24cm):**  
antiadherente, desmontable.  
Combinada: lisa y acanalada.

**Plate (35 x 24cm):**  
non-stick, removable.  
Combined: smooth and ribbed.

**Plaque (35 x 24cm):**  
antiadhésive, amovible.  
Combinée : lisse et rainurée.

REF: 05100004    EAN: 8425131510006     2



## Barbacoa Grill BBC-2200

### Grill Barbecue BBC-2200

### Grill Barbecue BBC-2200

**Seguridad:**  
bloqueo automático.

**Security:**  
automatic locking.

**Sécurité:**  
blocage automatique.

**Temperatura:**  
ajustable a 4 niveles.

**Temperature:**  
adjustable to 4 levels.

**Température:**  
réglable sur 4 niveaux.



**Placa (43 x 30cm):**  
antiadherente, desmontable.  
Combinada: lisa y acanalada.

**Plate (43 x 30cm):**  
non-stick, removable.  
Combined: smooth and ribbed.

**Plaque (43 x 30cm):**  
antiadhésive, amovible.  
Combinée : lisse et rainurée.

**Bandeja extraíble:**  
recoge grasas.

**Removable tray:**  
collects fats.

**Plateau amovible:**  
recueille les graisses.

REF: 05100204    EAN: 8425131510020     2



## Batidora de Mano HB-400

### Hand Blender HB-400

### Pied Mixeur HB-400

**Fácil extracción:**  
mediante dos botones a los lados.

**Easy extraction:**  
using two buttons on the sides.

**Extraction facile:**  
grâce à deux boutons sur les côtés.

**Cuchilla de 4 puntas:**  
en acero inoxidable y apta  
para el lavavajillas.

**4-point blade:**  
in stainless steel and  
dishwasher safe.

**Lame 4 pointes:**  
en acier inoxydable et passe  
au lave-vaisselle.



**Funciones:**  
5 velocidades regulables + turbo.

**Features:**  
5 adjustable speeds + turbo.

**Fonctions:**  
5 vitesses réglables + turbo.

**Motor:**  
de bajo ruido.

**Engine:**  
low noise.

**Moteur:**  
faible bruit.

**Acabado:**  
de acero inoxidable.

**Finish:**  
stainless steel.

**Finition:**  
acier inoxydable

REF: 05160504      EAN: 8425131516053       12



## Batidora de Mano HB-804

### Hand Blender HB-804

### Pied Mixeur HB-804

**Motor DC:**  
de bajo ruido.

**DC Engine:**  
low noise.

**Moteur DC:**  
faible bruit.

**Cuchilla de 4 puntas:**  
en acero inoxidable y apta  
para el lavavajillas.

**4-point blade:**  
in stainless steel and  
dishwasher safe.

**Lame 4 pointes:**  
en acier inoxydable et passe  
au lave-vaisselle.



**Funciones:**  
6 velocidades regulables + turbo. Botones  
cromados con retroiluminación azul.

**Features:**  
6 adjustable speeds + turbo.  
Chrome buttons with blue backlighting.

**Fonctions:**  
6 vitesses réglables + turbo. Boutons  
chromés avec rétroéclairage bleu.

**Acabado:**  
de acero inoxidable.

**Finish:**  
stainless steel.

**Finition:**  
acier inoxydable

REF: 05160304      EAN: 8425131516039       12



## Batidora de Mano HB-1200

### Hand Blender HB-1200

### Pied Mixeur HB-1200

Potente motor de 1200w:  
de bajo ruido.

Powerful 1200w motor:  
low noise.

Moteur puissant de 1200w:  
faible bruit.

Recipiente de picado:  
de 500ml con alfombrilla antideslizante.

Chopping container:  
500ml with non-slip mat.

Récipient à hacher:  
500 ml avec tapis antidérapant.



**Funciones:**  
control de velocidad por presión.

**Features:**  
pressure speed control.

**Fonctions:**  
contrôle de la vitesse par pression.

**Cuchilla de 2 puntas:**  
en acero inoxidable y apta  
para el lavavajillas.

**2-point blade:**  
in stainless steel and  
dishwasher safe.

**Lame 2 pointes:**  
en acier inoxydable et passe  
au lave-vaisselle.

REF: 05160404    EAN: 8425131516046     8



## Batidora de Mano HM-550

### Hand Mixer HM-550

### Mixeur Batteur HM-550

Expulsión de accesorios:  
por botón.

Accessories ejection:  
per button.

Éjection des accessoires:  
par bouton.

Varillas:  
de amasar y de mezclar.  
Aptas para el lavavajillas.

Rods:  
kneading and mixing.  
Dishwasher safe.

Crochets:  
pétrir et mélanger.  
Lave-vaisselle.



**Funciones:**  
4 velocidades regulables + turbo.

**Features:**  
4 adjustable speeds + turbo.

**Fonctions:**  
4 vitesses réglables + turbo.

**Motor:**  
de bajo ruido.

**Engine:**  
low noise.

**Moteur:**  
faible bruit.

REF: 05020104    EAN: 8425131502018     8



# Batidora de Vaso TB-1700

## Table Blender TB-1700

### Blender TB-1700

**Mandos:**  
ajuste automático para smoothies y picado de hielo. Indicadores LED.

**Controls:**  
automatic setting for smoothies and crushed ice. LED indicators.

**Contrôles:**  
réglage automatique pour smoothies et glace pilée. Indicateurs LED.

**Base:**  
antideslizante.

**Base:**  
non-slip.

**Base:**  
antidérapant.



**Seguridad:**  
doble cierre de seguridad en tapa y base.

**Security:**  
double safety closure on lid and base.

**Sécurité:**  
double fermeture de sécurité sur le couvercle et la base.

**Jarra:**  
de cristal graduada de 1,7L.

**Jug:**  
1.7L graduated glass.

**Récipient:**  
verre gradué de 1,7 L.

**Función Pulse:**  
para control de velocidad continuo.

**Pulse Function:**  
for continuous speed control.

**Fonction Pulse:**  
pour un contrôle continu de la vitesse

REF:

EAN:



05150104

8425131515018

4

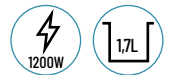

# Batidora de Vaso Sport SB-600x

## Sport Blender SB-600x

### Sport Blender SB-600x

**Cuchillas afiladas:**  
de acero inoxidable.

**Sharp blades:**  
in stainless steel.

**Lames tranchantes:**  
et acier inoxydable.

**Base:**  
antideslizante.

**Base:**  
non-slip.

**Base:**  
antidérapant.



**Vaso:**  
portable con asa de 0,6L de capacidad.

**Glass:**  
portable with handle of 0.6L capacity.

**Verre:**  
portable avec anse d'une capacité de 0,6 L.

**Funciones:**  
2 velocidades + función Pulse.  
Bloqueo de seguridad.

**Features:**  
2 speeds + Pulse function.  
Security lock.

**Fonctions:**  
2 vitesses + fonction Pulse.  
Blocage de sécurité.

REF:

EAN:



05170104

8425131517012

6



## Cortafiambres MS-15 Slicer MS-15 Trancheuse MS-15

**Seguridad:**  
pantalla protectora.

**Security:**  
protective screen.

**Sécurité:**  
écran de protection.

**Barra sujetabandeja:**  
de acero inox.  
Carro fácil limpieza.

**Tray holding bar:**  
stainless steel. Easy cleaning cart.

**Barre de maintien du plateau:**  
acier inoxydable.  
Chariot de nettoyage facile.



**Hoja:**  
desmontable y cuchilla lisa de precisión.  
Grosor de corte regulable (1-15mm).

**Blade:**  
detachable and smooth precision blade.  
Adjustable cutting thickness (1-15mm).

**Feuille:**  
lame de précision amovible et lisse.  
Épaisseur de coupe réglable (1-15 mm).

**Base:**  
antideslizante.  
Tamaño compacto.

**Base:**  
non-slip.  
Compact size.

**Base:**  
antidérapant.  
Format compact.

REF: 05040004    EAN: 8425131504005     2



## Freidora F-2500 Deep Fryer F-2500 Friteuse F-2500

**Cuba extraíble:**  
junto con las resistencias  
para una fácil limpieza.

**Removable tank:**  
along with the heating  
elements for easy cleaning.

**Réservoir amovible:**  
avec les résistances  
pour un nettoyage facile.



**Tapa con filtro y ventana:**  
extraíble, apto para el lavavajillas.

**Lid with filter and window:**  
removable, dishwasher safe.

**Couvercle avec filtre et hublot:**  
amovible, passe au lave-vaisselle.

**Programador de tiempo:**  
ajustable hasta 30 min.

**Time programmer:**  
adjustable up to 30 min.

**Programmeur horaire:**  
réglable jusqu'à 30 min.

**Temperatura:**  
regulable 130°-190°C.

**Temperature:**  
adjustable 130°-190°C.

**Température:**  
réglable 130°-190°C.

**Cestillo extraíble:** con calentamiento rápido y asa abatible.  
**Removable basket:** with rapid heating and folding handle.  
**Panier amovible:** avec chauffage rapide et anse inclinable.

REF: 05120004    EAN: 8425131512000     2



# Robot Amasador FP-5500M

## Stand Mixer FP-550M

### Robot Pâtissier FP-550M

Tapa antisalpicaduras:  
transparente.  
Splash-proof lid:  
transparent.  
Couvercle anti-projections:  
transparent.

Características:  
movimiento planetario,  
nivel bajo de sonido.  
Characteristics:  
planetary movement,  
low sound level.  
Caractéristiques:  
mouvement planétaire,  
faible niveau sonore.



“Pop-Up”:  
sistema de elevado de cabeza.  
“Pop-Up”:  
tilting system.  
“Pop-Up”:  
système de levage de tête.

Funciones:  
7 velocidades + función Pulse.  
Features:  
7 speed levels + Pulse function.  
Fonctions:  
7 vitesses + fonction Pulse.

Base:  
antideslizante.  
Base:  
non-slip.  
Base:  
antidérapant.

Accesorios: gancho amasador y batidor plano antiadherentes y batidor de varillas aptos para el lavavajillas.

Accessories: non-stick dough hook and flat beater and dishwasher-safe whisk.

Accessoires: crochet pétrisseur antiadhésif et batteur plat et fouet lavable au lave-vaisselle.



REF: 05010804      EAN: 8425131501080       1



## Accesorios para Amasadora FP-5500M

### Stand Mixer accessories FP-5500M

### Accessoires Robot pâtissier FP-5500M

**NEW**



Jarra de cristal graduada, 1,5L de capacidad.  
1.5L capacity graduated glass jug.  
Pichet en verre gradué. Capacité de 1,5 L.



Picadora de carne con bandeja de alimentos.  
Meat grinder with food tray.  
Hachoir à viande avec plateau alimentaire.



Cortadora y picadora de verduras (3 cuchillas).  
Vegetable slicer and chopper (3 blades).  
Coupe-légumes et hachoir (3 lames).

REF: 05010904      EAN: 8425131501097       1

# Robot Amasador FP-4000

## Stand Mixer FP-4000

### Robot Pâtissier FP-4000

Tapa antisalpicaduras:  
transparente.  
Splash-proof lid:  
transparent.  
Couvercle anti-projections:  
transparent.

Base:  
antideslizante.  
Base:  
non-slip.  
Base:  
antidérapant.



“Pop-Up”:  
sistema de elevado de cabeza.  
“Pop-Up”:  
tilting system.  
“Pop-Up”:  
système de levage de tête.

Funciones:  
6 velocidades + función Pulse.  
Features:  
6 speed levels + Pulse function.  
Fonctions:  
6 vitesses + fonction Pulse.

**Accesorios:** gancho amasador y batidor plano antiadherentes y batidor de varillas aptos para el lavavajillas.

**Accessories:** non-stick dough hook and flat beater and dishwasher-safe whisk.

**Accessoires:** crochet pétrisseur antiadhésif et batteur plat et fouet lavable au lave-vaisselle.



REF: 05010704    EAN: 8425131501035     2



# Procesador de Alimentos FP-3500X

## Food Processor FP-3500X

### Robot de Cuisine FP-3500X

**Multifunción:**  
picadora, batidora y amasadora.

**Multifunction:**  
chopper, mixer and kneader.

**Multifonction:**  
hachoir, mixeur et pétrin.



**Cajón integrado:**  
para almacenamiento de cuchillas.

**Integrated drawer:**  
for blade storage.

**Tiroir intégré:**  
pour le rangement des lames.



**5 cuchillas de acero inoxidable:**  
corte fino/grueso, triturado fino/grueso y corte de patatas fritas.

**5 stainless steel blades:**  
fine/coarse cutting, fine/coarse grinding and cutting of French fries.

**5 lames inox:**  
coupe fine/grossière, broyage fin/grossier et découpe de frites.

**Características:**  
2 velocidades + función Pulse.  
Bloqueo de seguridad.

**Features:**  
2 speeds + Pulse function.  
Security lock.

**Fonctions:**  
2 vitesses + fonction Pulse.  
Blocage de sécurité.

REF:

EAN:



05010104

8425131501011

2



# Robot de Cocina MC-2500

## Multifunctional Cooker MC-2500

### Robot de Cuisine MC-2500

**Accesorios:**  
cestillo, 2 vaporeras con tapa, espátula, vaso medidor 100ml, barra de mariposa y llave.

**Accessories:**  
basket, 2 steamers with lid, spatula, 100ml measuring cup, butterfly bar and key.

**Accessoires:**  
panier, 2 cuiseurs vapeur avec couvercle, spatule, verre doseur 100 ml, barre papillon et clé.

**Pantalla LED:**  
báscula integrada 1-5kg.

**LED screen:**  
integrated scale 1-5kg.

**Écran LED:**  
balance intégrée 1-5kg.



**Seguridad:**  
doble cierre de seguridad en tapa y bol.

**Security:**  
double safety closure on lid and bowl.

**Sécurité:**  
double fermeture de sécurité sur le couvercle et bol.

**Multifunción:**  
cocinar al vapor, mezclar, licuar, triturar, picar, agitar, emulsionar, amasar, cocinar, calentar y hervir.

**Multifunction:**  
steaming, mixing, blending, mashing, chopping, stirring, emulsifying, kneading, cooking, heating and boiling.

**Multifonction:**  
cuire à la vapeur, mélanger, mélanger, écraser, hacher, remuer, émulsionner, pétrir, cuire, chauffer et faire bouillir.

REF:

EAN:



05010604

8425131501066

1



# Robot de Cocina MC-2000

## Multifunctional Cooker MC-2000

### Robot de Cuisine MC-2000

#### Accesorios:

cestillo, 2 vaporeras con tapa, espátula, vaso medidor 100ml y funda para cuchillas.

#### Accessories:

basket, 2 steamers with lid, spatula, 100ml measuring cup, and blade cover.

#### Accessoires:

panier, 2 cuiseurs vapeur avec couvercle, spatule, verre doseur 100 ml, et couvre-lame.



**Pantalla táctil HD de uso intuitivo:**  
en color de 7". Báscula integrada 1-5kg

**Intuitive HD touch screen:**  
in 7" color. Integrated scale 1-5kg

**Écran tactile HD intuitif:**  
en couleur 7". Balance intégrée 1-5kg

**Base:**  
antideslizante.

**Base:**  
anti-slip.

**Base:**  
antidérapant.

#### Características:

función Pulse, reverse y autolimpiado.  
Velocidad 1-10 y temperatura 30-120°C.

#### Features:

Pulse, reverse and self-cleaning function.  
Speed 1-10 and temperature 30-120°C.

#### Caractéristiques:

Fonction Pulse, d'inversion et d'auto-nettoyage.  
Vitesse 1-10 et température 30-120°C.

#### Multifunción:

cocinar al vapor, mezclar, licuar, triturar, picar, agitar, emulsionar, amasar, cocinar, calentar y hervir.

#### Multifunction:

steaming, mixing, blending, mashing, chopping, stirring, emulsifying, kneading, cooking, heating and boiling.

#### Multifonction:

cuire à la vapeur, mélanger, mélanger, écraser, hacher, remuer, émulsionner, pétrir, cuire, chauffer et faire bouillir.

REF: 05010504      EAN: 8425131501059       1



# Olla a Presión de Inducción Programable PC-1100-5

## Programmable Induction Pressure Cooker PC-1100-5

### Autocuiseur Induction Programmable PC-1100-5



REF: 05140004    EAN: 8425131514004     1

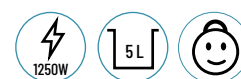

## Accesorios para Olla a presión de Inducción PC-1100-5

### Induction Pressure Cooker Accessories PC-1100-5

### Accessoires pour Autocuiseur Induction PC-1100-5



REF: 055140402    EAN: 8425131551443     1

# Repuestos

SPARE PARTS | PIÈCES DÉTACHÉES



# Abrelatas Industrial Desmontable NSF

## Removable NSF Industrial Can opener

### Ouvre-boîtes Industriel Amovible NSF

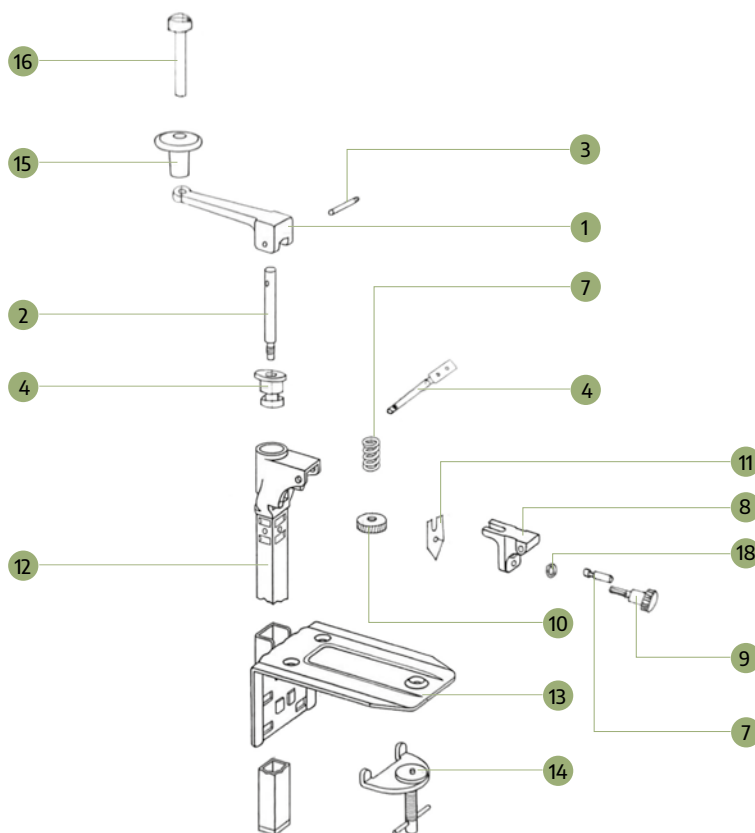

		Cant. Amot. Mont.	Niquelado Nickel plated Nickelé	Acero inoxidable Stainless Steel Acier inoxydable
1.	Manilla Abrelatas   Can opener handle   Poignée ouvre-boîtes		011170202	
2.	Eje de Manilla   Wheel holder shaft   Axe de poignée		011070302	
3.	Tornillo de la manilla   Handle screw   Vis de la poignée		011070202	
4.	Casquillo   Bushing   Douille		011170402	
5.	Pack Pasador de bola y chapita para barra Can opener detent pin pack   Pack cheville à douille et plaque	6 uds.	011170602	
6.	Pasador barra   Bar screw   Vis de la barre		011070602	
7.	Muelle   Spring   Ressort		011170702	
8.	Balancín portacuchillas   Blade holder   Porte-lames		011170802	
9.	Tornillo sujeción cuchilla   Blade holder screw   Vis de fixation lame		011171102	
10.	Roldana   Gear wheel   Molette		011071202	
11.	Cuchilla   Blade   Lame		011071302	
12.	Barra   Bar   Barre		011180302	
13.	Plato   Base plate   Plateau		011170502	011180502
14.	Tornillo para sujeción   Clamp assembly   Vis de fixation		011071502	
15.	Pomo de la manilla   Handle knob   Bouton de la poignée		011071602	
16.	Eje del pomo   Knob spindle   Axe du bouton poignée			011170102
17.	Eje posicionador cuchilla   Blade positioning shaft   Axe de positionnement de lame			011171002
18.	Junta tórica   O-ring   Joint torique			011170902

# Abrelatas Industrial Tradicional

## Traditional Industrial Can Opener

### Ouvre-boîte Industriel Traditionnel

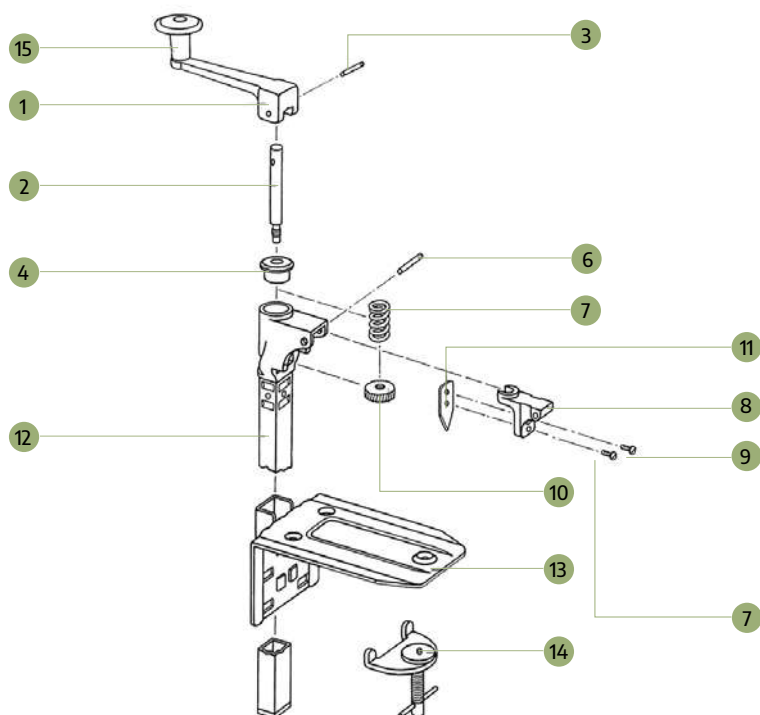

	Niquelado Nickel plated Nickelé	Acero inoxidable Stainless Steel Acier inoxydable
1. Manilla Abrelatas   Can opener handle   Poignée ouvre-boîtes	011070102	
2. Eje de Manilla   Wheel holder shaft   Axe de poignée	011070302	
3. Tornillo de la manilla   Handle screw   Vis de la poignée	011070202	
4. Casquillo   Bushing   Douille	011070402	
6. Pasador barra   Bar screw   Vis de la barre	011070602	
8. Balancín portacuchillas   Blade holder   Porte-lames	011070802	
9. Tornillo sujeción cuchilla   Blade holder screw   Vis de fixation lame	011071102	
10. Roldana   Gear wheel   Molette	011071202	
11. Cuchilla   Blade   Lame	011071302	
12. Barra   Bar   Barre	011130502	
13. Plato   Base plate   Plateau	011071402	011131402
14. Tornillo para sujeción   Clamp assembly   Vis de fixation	011071502	
15. Pomo de la manilla   Handle knob   Bouton de la poignée	011071602	

# Sacacorchos de Pared TRADICIONAL

## TRADITIONAL Wall-mounted Corkscrew

### Tire-bouchon Mural TRADITIONNEL

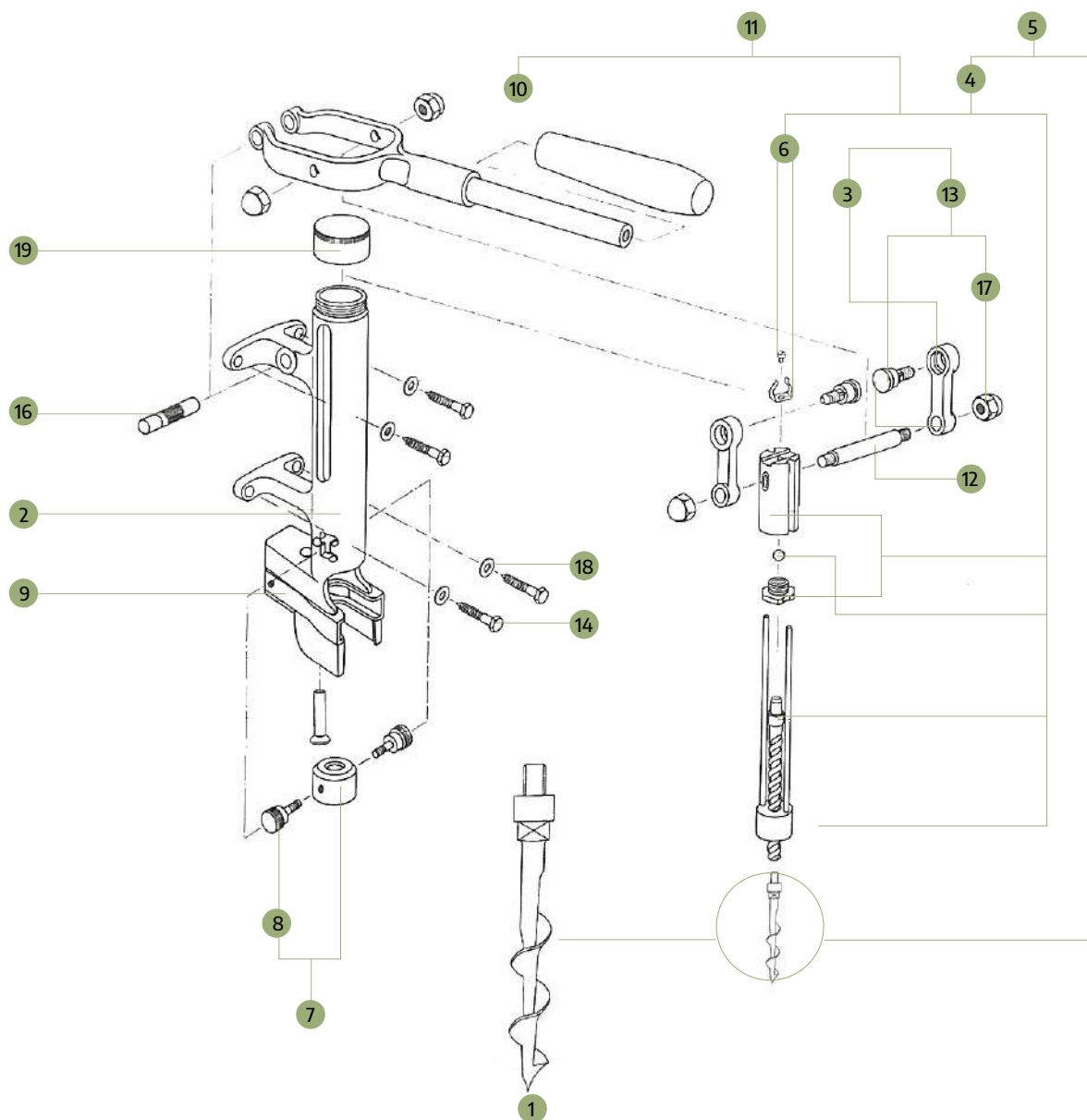

	Cant. Anot. Mont.	Cromado Chrome-plated Chromé	Cromado mate Chrome matted Chromé mat	Cobre envejecido Old-coppered Cuirve vieilli	Níquel negro Black-nickel Nickel noir	Negro Black Noir	Oro Gold Or
1. Pack espiga universal   Universal male worm pack   Pack mèche universelle mâle	6 uds.	01040701					
2. Cuerpo   Body   Corps		09920200212	09920200218	09920200216	09920200215	0104062002	0104602002
3. Biela   Connecting rod   Bielle	2 uds.	0992050212	0992060218	0992060216	0992060215	0104066002	0104606002
4. Movimiento interior sin espiga Full internal mechanism without worm   Mécanisme intérieur complet sans mèche		099203202					
5. Movimiento interior con espiga   Full internal mechanism with worm   Mécanisme intérieur complet avec mèche		099203102					
6. Tornillo + Muelle sujeción   Screw and Spring   Vis et ressort		099201802					
7. Regulador de extracción corcho + Tornillo regulador   Cork extraction regulator   Régulateur d'extraction du bouchon avec vis de régulation	2 uds.		099202502			0104062912	0104602912
8. Tornillo regulador   Regulating screws   Vis de régulation	2 uds.		099202512			0104062902	0104602902
9. Conjunto Pinza sujeta botellas   Bottle holder set   Set pince à bouteilles			099202802			0104067002	0104602802
10. Palanca horquilla   Fork lever   Fourche		0992030212	0992030218	0992030216	0992030215	0992032406	0104608002
11. Palanca horquilla completa   Full fork lever   Fourche complète		09920300212	09920300218	09920300216	09920300215	09920302406	0104603002
12. Pasador biela barra   Bar lock pin   Cheville cylíndrica				09920902			0104600602
16. Pasador   Bar spindle pin   Cheville cylíndrica			09920170212	09920170216	09920170215		0104601702
13. Tornillo + tuerca de la biela   Bar spindle pin with screw   Vis et écrou de bielle	2 y 2 uds.	0992080212	0099398002	0099258002	0099248002	0104068002	0104600302
14. Tornillo anclaje sacacorchos a pared Corkscrew wall anchor screw   Vis d'ancrage tire-bouchon au mur	4 uds.		099202602	099202605	099202604	099202606	099202660
15. Tornillo anclaje sacacorchos a soporte   Screw anchoring corkscrew to backing   Vis d'ancrage tire-bouchon au support	4 uds.		099202603			099202616	099202661
20. Tornillo anclaje soporte a pared Screw anchoring support to wall   Vis d'ancrage support au mur	3 uds.		0992090212	0992090213	0992090214	0992090215	0992090216
17. Tuerca de la biela   Connecting rod nut   Écrou de bielle	4 uds.	0992050212	0992070218	0992070216	0992070215	0104060502	0104600502
18. Arandela   Washer   Rondelle	4 uds.		099202702	099202703	099202704	099202705	099202706
19. Tapón   Cover   Bouchon		09920190212	09920190218	09920190216	09920190215	09920190204	0104601902

# Sacacorchos de Pared 110

## 110 Wall-mounted Corkscrew

### Tire-bouchon Mural 110

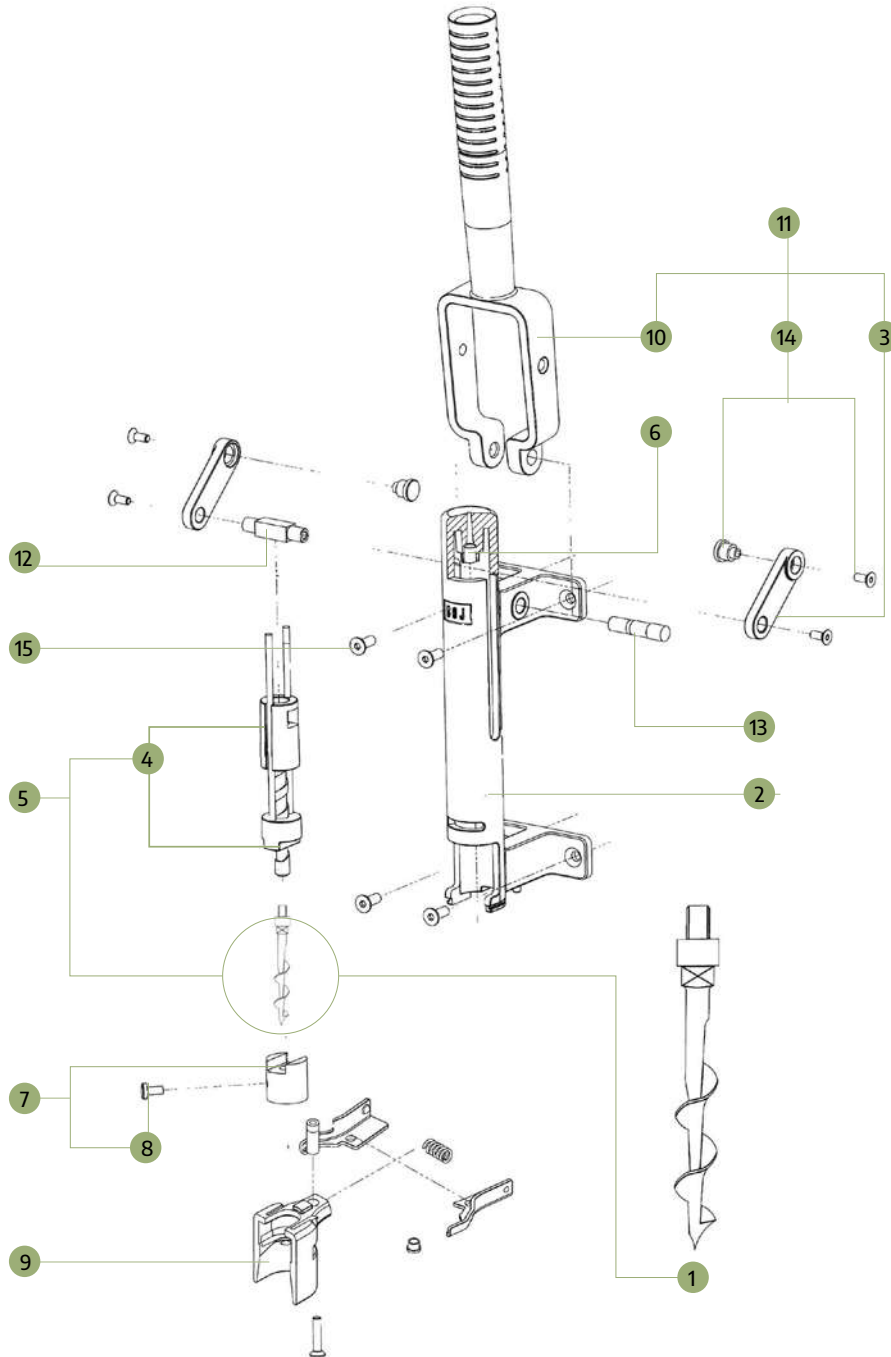

		Cant. Amot. Mont.	Cromado Chrome-plated Chromé	Cobre envejecido Old-coppered Cuiivre vieilli	Níquel negro Black-nickeled Nickel noir	Negro Black Noir	Natural Gold Or
1.	Pack Espiga Universal   Universal male worm pack   Pack mèche universelle mâle	6 uds.			01040701		
2.	Cuerpo   Body   Corps		0104070102	0104080102	0104090102	0104100102	0104140102
3.	Biela   Connecting rod   Bielle	2 uds.	0104070202	0104080202	0104090202	0104100202	0104140202
4.	Movimiento interior sin espiga Full internal mechanism without worm   Mécanisme intérieur complet sans mèche				010407302		
5.	Movimiento interior con espiga Full internal mechanism with worm   Mécanisme intérieur complet avec mèche				010407402		
6.	Imán de sujeción   Fastening magnet   Aimant de fixation				010407602		
7.	Regulador de extracción del corcho + Tornillo regulador Cork extraction regulator   Régulateur d'extraction du bouchon avec vis de régulation	2 uds.			010407702		
8.	Tornillo regulador   Regulating screws   Vis de régulation	2 uds.			010407802		
9.	Conjunto Pinza sujeta botellas   Bottle holder set   Set pince à bouteilles				010407902		
10.	Palanca horquilla   Fork lever   Fourche		010407102	0104081102	0104091102	0104101102	0104141102
11.	Palanca horquilla completa   Full fork lever   Fourche complète		0104071002	0104081002	0104091002	0104101002	0104141002
12.	Pasador biela barra   Bar lock pin   Cheville cylindrique				010408202		
13.	Pasador   Bar spindle pin   Cheville cylindrique		09920170212	09920170216	09920170215	09920170215	09920170212
14.	Tornillo + tuerca de la biela   Bar spindle pin with screw   Vis et écrou de bielle	2 y 2 uds.	0104070302	0104080302	0104090302	0104100302	0104140302
15.	Tornillo anclaje sacacorchos a pared Corkscrew wall anchor screw   Vis d'ancrage tire-bouchon au mur	4 uds.			010408602		
16.	Tornillo anclaje soporte a pared   Screw anchoring support to wall   Vis d'ancrage support au mur	3 uds.			010408702		

# Sacacorchos de Pared 110 LUX

## 110 LUX Wall-mounted Corkscrew

### Tire-bouchon Mural 110 LUX

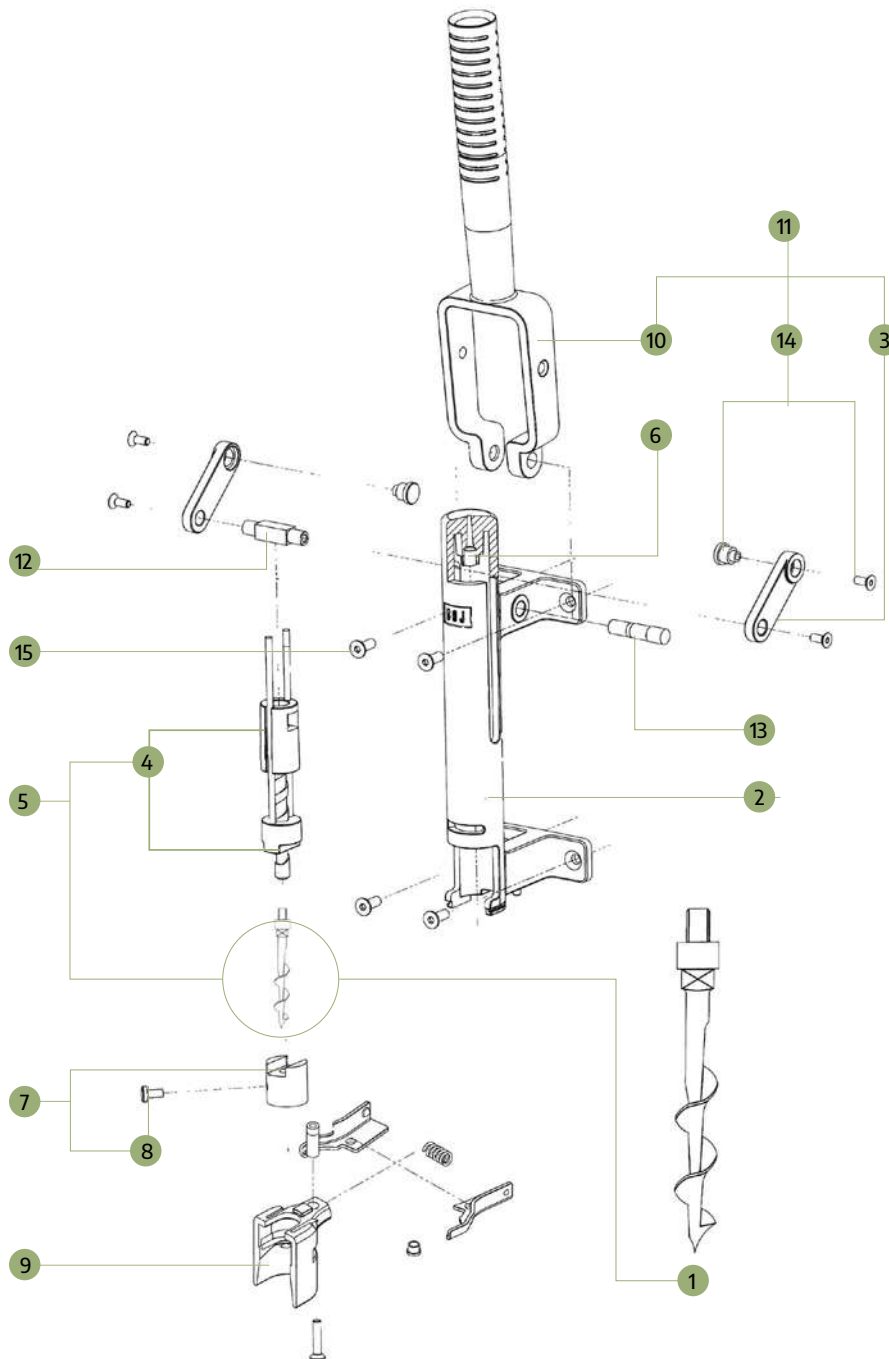

		Cant.	Rojo cereza Cherry red Rouge cerise	Gris acero Steel grey Gris acier	Ocre suave Ochre brown Ocre doux	Azul starnight Starnight blue Bleu starnight	Verde esme. Emergreen Vert émeraue.	Azul habana Habana blue Bleu habane	Marrón café Coffee brown Marron café	Negro puro Pure black Noir pur
1.	<b>Pack Espiga Universal</b> Universal male worm pack   Pack mèche universelle mâle	6 uds.	01040701							
2.	<b>Cuerpo</b>   Body   Corps		0104210102	0104220102	0104230102	0104240102	0104250102	0104260102	0104270102	0104280102
3.	<b>Biela</b>   Connecting rod   Bielle	2 uds.	0104210202	0104220202	0104230202	0104240202	0104250202	0104260202	0104270202	0104280202
4.	<b>Movimiento interior sin espiga</b> Full internal mechanism without worm Mécanisme intérieur complet sans mèche		010407302							
5.	<b>Movimiento interior con espiga</b> Full internal mechanism with worm Mécanisme intérieur complet avec mèche		010407402							
6.	<b>Imán de sujeción</b>   Fastening magnet   Aimant de fixation		010407602							
7.	<b>Regulador de extracción del corcho + Tornillo regulador</b> Cork extraction regulator   Régulateur d'extraction du bouchon avec vis de régulation	2 uds.	010407702							
8.	<b>Tornillo regulador</b>   Regulating screws   Vis de régulation	2 uds.	010407802							
9.	<b>Conjunto Pinza sujeta botellas</b> Bottle holder set   Set pince à bouteilles		010407902							
10.	<b>Palanca horquilla</b>   Fork lever   Fourche		010421102	010422102	010423102	010424102	010425102	010426102	010427102	010428102
11.	<b>Palanca horquilla completa</b>   Full fork lever   Fourche complète		010421002	010422002	010423002	010424002	010425002	010426002	010427002	010428002
12.	<b>Pasador biela barra</b>   Bar lock pin   Cheville cylindrique		010408202							
13.	<b>Pasador</b>   Bar spindle pin   Cheville cylindrique		09920170212							
14.	<b>Tornillo + tuerca de la biela</b> Bar spindle pin with screw   Vis et écrou de bielle	2 y 2 uds.	0104210302	0104220302	0104230302	0104240302	0104250302	0104260302	01044140302	01044140302
15.	<b>Tornillo anclaje sacacorchos a pared</b> Corkscrew wall anchor screw   Vis d'ancrage tire-bouchon au mur	4uds.	010408602							
16.	<b>Tornillo de anclaje soporte a pared</b> Screw anchoring support to wall   Vis d'ancrage support au mur	3 uds.	010408702							

# Sacacorchos de Mesa

## Table-mounted Corkscrew

### Tire-bouchon de Comptoir

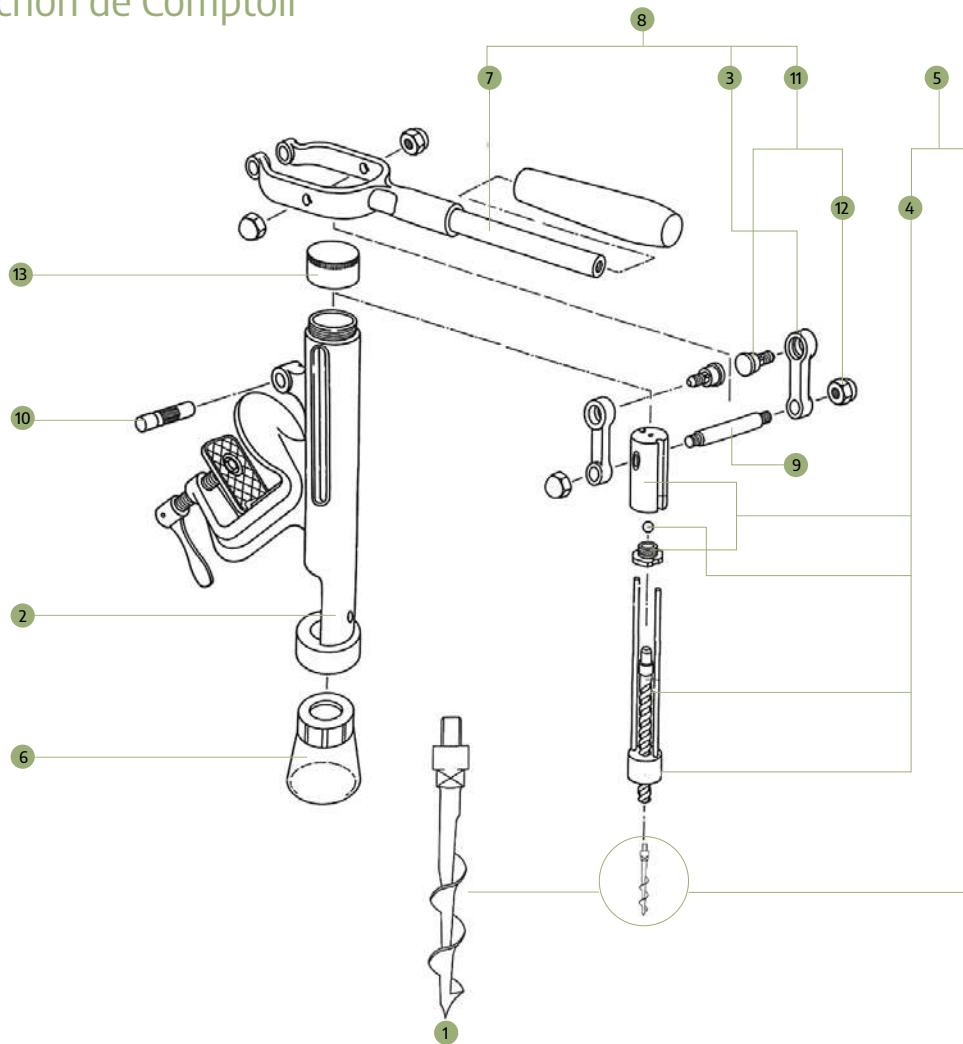

		Cant. Amot. Mont.	Cromado Chrome-plated Chromé	Negro Black Noir
1.	Pack Espiga Universal   Universal male worm pack   Pack mèche universelle mâle	6 uds.	01040701	
2.	Cuerpo   Body   Corps		09920150212	09920150215
3.	Biela   Connecting rod   Bielle	2 uds.	0992060212	0104066002
4.	Movimiento interior sin espiga Full internal mechanism without worm   Mécanisme intérieur complet sans mèche		099203202	
5.	Movimiento interior con espiga Full internal mechanism with worm   Mécanisme intérieur complet avec mèche		099203102	
6.	Protector cónico de plástico   Conical plastic protector   Protecteur conique en plastique		099202902	
7.	Palanca horquilla   Fork lever   Fourche		0992030212	0992032406
8.	Palanca horquilla completa   Full fork lever   Fourche complète		09920300212	09920302406
9.	Pasador biela barra   Bar lock pin   Cheville cylindrique	2 y 2 uds.	09920902	
10.	Pasador   Bar spindle pin   Cheville cylindrique	4uds.	09920170212	
11.	Tornillo + tuerca de la biela   Bar spindle pin with screw   Vis et écrou de bielle		0099128002	0104068002
12.	Tuerca de la biela   Connecting rod nut   Écrou de bielle		0992050212	0104060502
13.	Tapón   Cover   Bouchon		099201602	099201612

# Vinoteca Integrable W-0455

## Fully Integrable Wine Cellar W-0455

### Cave à Vin Intégrable W-0455

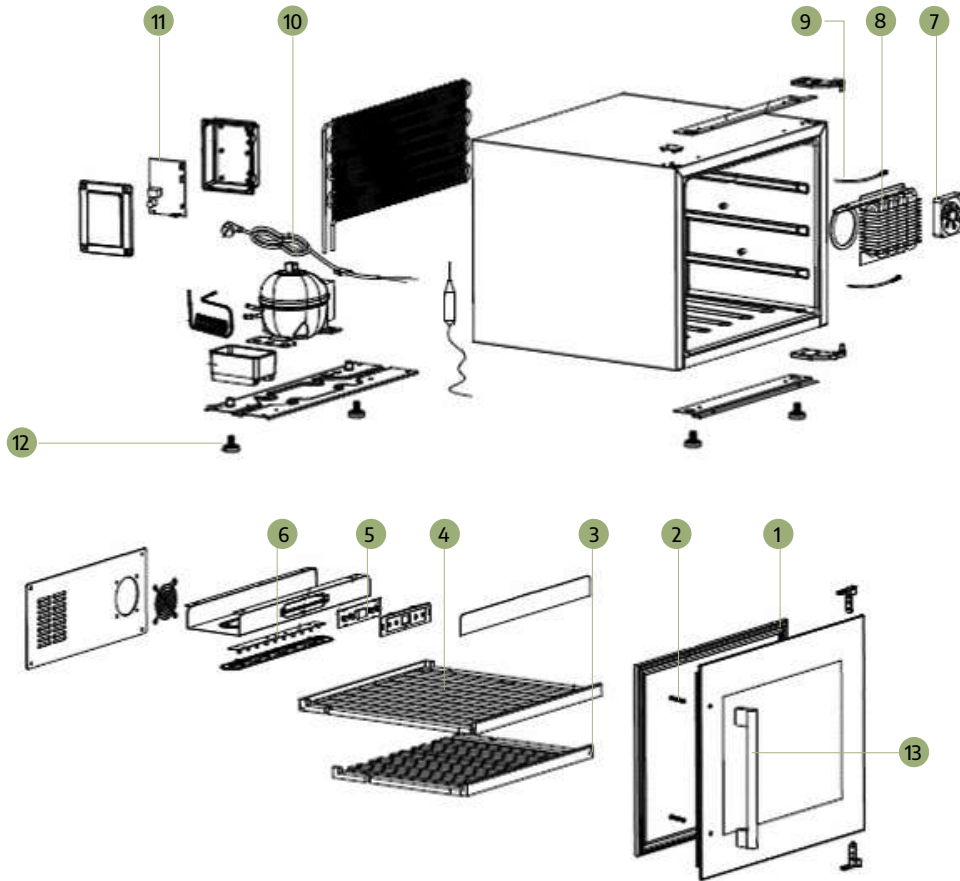

	SKU
1. Junta de la puerta   Door seal   Joint de porte	07702302
2. Tornillo   Screw   Vis	07703102
3. Balda de madera   Wooden shelf   Tablette en bois	07702802
4. Balda de madera adicional   Additional wooden shelf   Tablette en bois supplémentaire	07702402
5. Pantalla de información   Information display   Écran d'information	07702502
6. Plato de la lámpara   Lamp plate   Plaque de lampe	07701102
7. Ventilador 1   Fan 1   Ventilateur 1	07701402
8. Evaporador de aletas   Fin evaporator   Evaporateur à ailettes	07703902
9. Sensor   Sensor   Capteur	07700702
10. Cable enchufe   Cable plug   Connecteur de câble	07700902
11. Placa base   Base plate   Plaque de base	07702602
12. Pie   Foot   Pied	07703002
13. Asa   Handle   Poignée	07702202

# Vinoteca Integrable W-0595

## Fully Integrable Wine Cellar W-0595

### Cave à Vin Intégrable W-0595

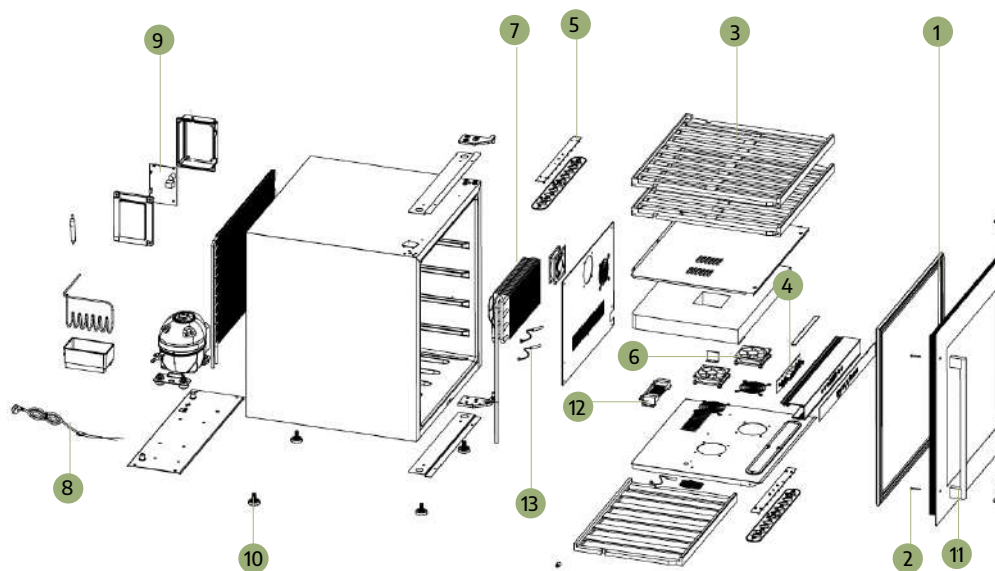

	SKU
1. Junta de la puerta   Door seal   Joint de porte	07702702
2. Tornillo   Screw   Vis	07703102
3. Balda de madera   Wooden shelf   Tablette en bois	07702802
4. Pantalla de información   Information display   Écran d'information	07700302
5. Plato de la lámpara   Lamp plate   Plaque de lampe	07702402
6. Ventilador 1   Fan 1   Ventilateur 1	07701402
7. Evaporador de aletas   Fin evaporator   Evaporateur à ailettes	07700602
8. Cable enchufe   Cable plug   Connecteur de câble	07700902
9. Placa base   Base plate   Plaque de base	07700802
10. Pie   Foot   Pied	07703002
11. Asa   Handle   Poignée	07704002
12. Calentador PTC   PTC heater   Chauffage PTC	07702902
13. Bisagra   Hinge   Charnière	07703802

# Vinoteca Encastrable W-0820

## Built-in Undercounter Wine Cellar W-0820

### Cave à Vin Encastrée sous comptoir W-0820

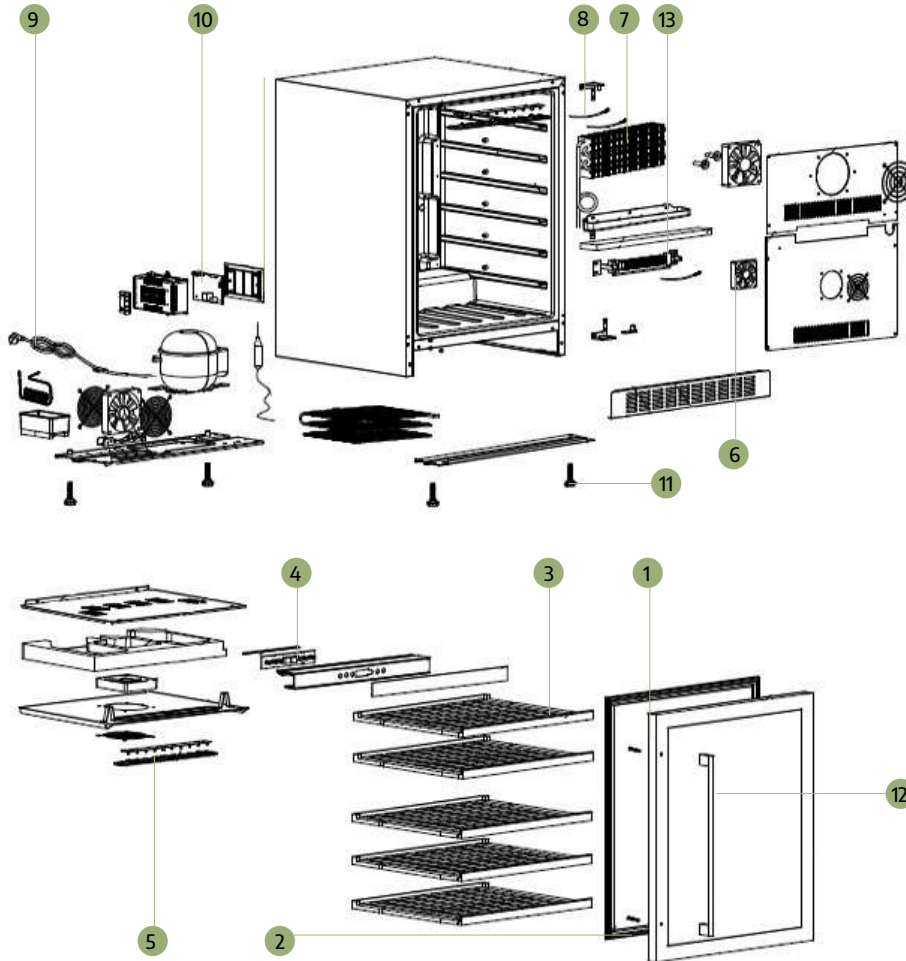

	SKU
1. Junta de la puerta   Door seal   Joint de porte	07700102
2. Tornillo   Screw   Vis	07701302
3. Balda de madera   Wooden shelf   Tablette en bois	07700202
4. Pantalla de información   Information display   Écran d'information	07700302
5. Plato de la lámpara   Lamp plate   Plaque de lampe	07701102
6. Ventilador 1   Fan 1   Ventilateur 1	07701402
7. Evaporador de aletas   Fin evaporator   Evaporateur à ailettes	07700602
8. Sensor   Sensor   Capteur	07700702
9. Cable enchufe   Cable plug   Connecteur de câble	07700902
10. Placa base   Base plate   Plaque de base	07700802
11. Pie   Foot   Pied	07701002
12. Asa   Handle   Poignée	07700002
13. Calentador PTC   PTC heater   Chauffage PTC	07700502

# Vinoteca Encastrable W-0821

## Built-in Undercounter Wine Cellar W-0821

### Cave à Vin Encastrée sous comptoir W-0821

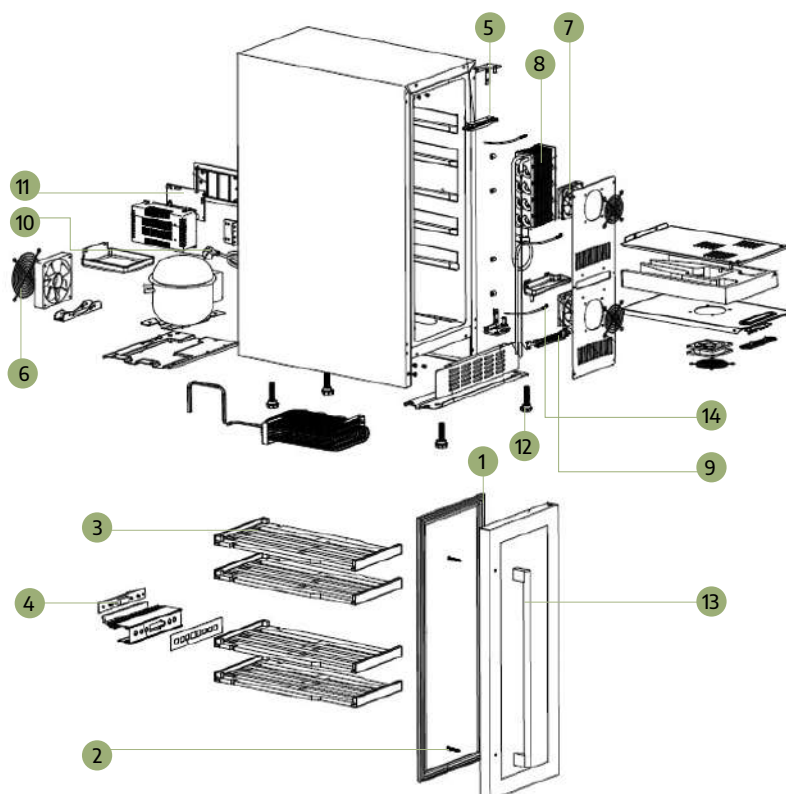

	SKU
1. Junta de la puerta   Door seal   Joint de porte	07703202
2. Tornillo   Screw   Vis	07701302
3. Balda de madera   Wooden shelf   Tablette en bois	07703302
4. Pantalla de información   Information display   Écran d'information	07700302
5. Plato de la lámpara   Lamp plate   Plaque de lampe	07703702
6. Ventilador 1   Fan 1   Ventilateur 1	07703402
7. Ventilador 2   Fan 2   Ventilateur 2	07701402
8. Evaporador de aletas   Fin evaporator   Evaporateur à ailettes	07703902
9. Sensor   Sensor   Capteur	07700702
10. Cable enchufe   Cable plug   Connecteur de câble	07700902
11. Placa base   Base plate   Plaque de base	07700802
12. Pie   Foot   Pied	07701002
13. Asa   Handle   Poignée	07700002
14. Calentador PTC   PTC heater   Chauffage PTC	07703502

# Vinoteca Libre Instalación W-1285

## Free Standing Wine Cellar W-1285

### Cave à Vin Autoportante W-1285

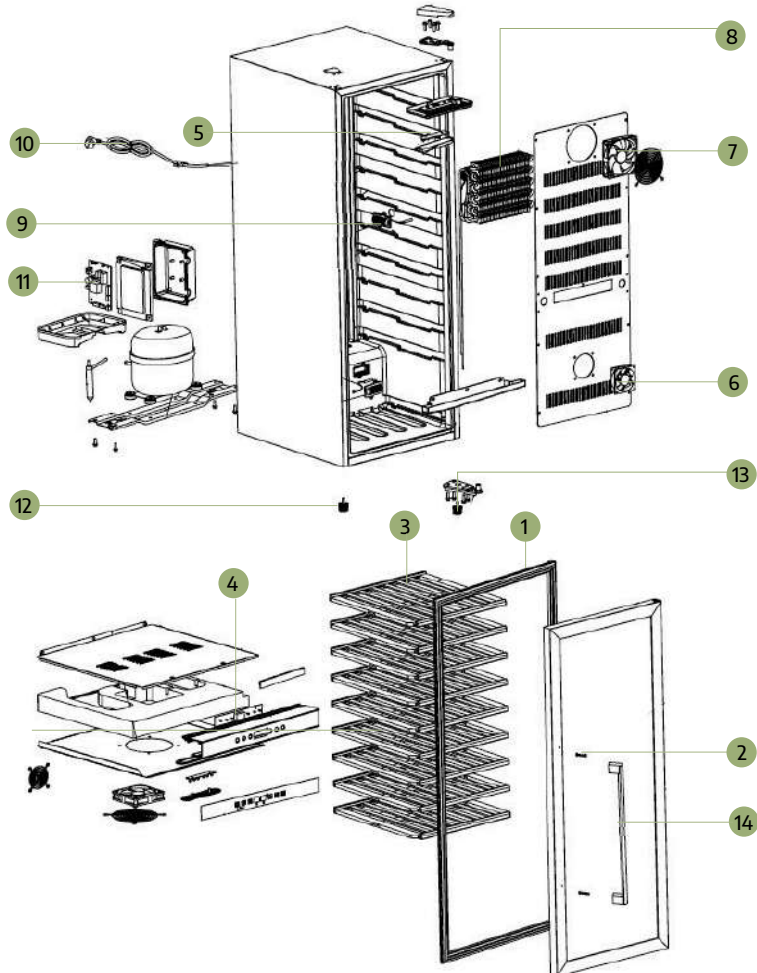

	SKU
1. Junta de la puerta   Door seal   Joint de porte	07701602
2. Tornillo   Screw   Vis	07701302
3. Balda de madera   Wooden shelf   Tablette en bois	07701702
4. Pantalla de información   Information display   Écran d'information	07701802
5. Plato de la lámpara   Lamp plate   Plaque de lampe	07702102
6. Ventilador 1   Fan 1   Ventilateur 1	07701402
7. Ventilador 2   Fan 2   Ventilateur 2	07701202
8. Evaporador de aletas   Fin evaporator   Evaporateur à ailettes	07702002
9. Sensor   Sensor   Capteur	07700702
10. Cable enchufe   Cable plug   Connecteur de câble	07700902
11. Placa base   Base plate   Plaque de base	07700802
12. Pie   Foot   Pied	07704202
13. Pie corto   Short foot   Pied court	07704102
14. Asa   Handle   Poignée	07700002

# Vinoteca Libre Instalación W-1770

## Free Standing Wine Cellar W-1770

### Cave à Vin Autoportante W-1770

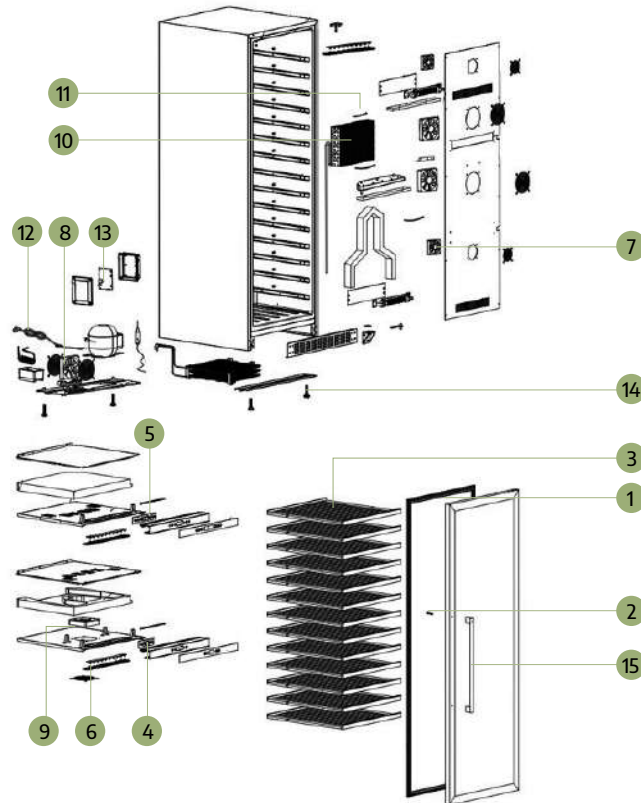

	SKU
1. Junta de la puerta   Door seal   Joint de porte	07704302
2. Tornillo   Screw   Vis	07704402
3. Baldas de madera   Wooden shelf   Tablette en bois	07704502
4. Pantalla de información   Inf. Bottom information display   Écran d'information	07704602
5. Pantalla de información sup.   Top information display   Écran d'information supérieur	07704702
6. Plato de la lámpara   Lamp plate   Plaque de lampe inférieur	07704802
7. Ventilador 1   Fan 1   Ventilateur 1	07704902
8. Ventilador 2   Fan 2   Ventilateur 2	07705002
9. Ventilador 3   Fan 3   Ventilateur 3	07705102
10. Evaporador de aletas   Fin evaporator   Evaporateur à ailettes	07705202
11. Sensor   Sensor   Capteur	07705302
12. Cable enchufe   Cable plug   Connecteur de câble	07705402
13. Placa base   Base plate   Plaque de base	07705502
14. Pie   Foot   Pied	07705602
15. Asa   Handle   Poignée	07705702









1905

**BOJ OLAÑETA, S.L.U.**

Matsaria, 21

20600 Eibar (Gipuzkoa) SPAIN

Tel.: (+34) 943 82 00 71 | [info@bojglobal.com](mailto:info@bojglobal.com)

[www.bojglobal.com](http://www.bojglobal.com)



Fotografías no contractuales.

BOJ Olañeta S.L.U. se reserva el derecho de modificar las características de sus productos sin previo aviso.